

**OPERATION MANUAL**

# ***YANMAR***

## ***MARINE DIESEL ENGINE***

***6LYA-STP, 6LY2A-STP***

---

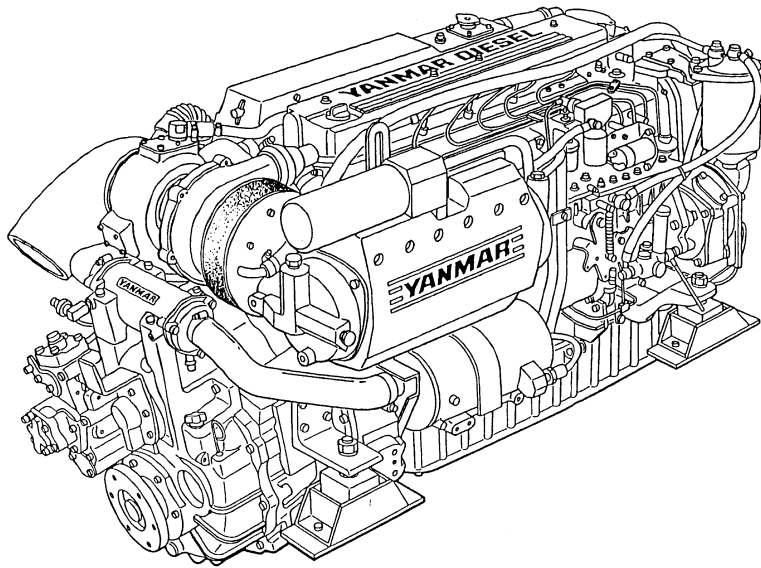

**Be sure to read this manual for safe and proper operation.  
Store this manual carefully after use.**

Congratulations on your choice of  
YANMAR product from YANMAR DIESEL ENGINE CO., LTD.  
This manual describes operation, periodic inspection and  
maintenance servicing for the ENGINE manufactured by  
YANMAR DIESEL ENGINE CO., LTD.  
Please read this manual carefully before use, and operate  
your engine properly under the optimum conditions, should  
you have any questions or concerns, please do not hesitate to  
contact your nearest dealer or distributor.

### California Proposition 65 Warning

Diesel engine exhaust and some of its  
constituents are known to the State of  
California to cause cancer, birth defects,  
and other reproductive harm.

### California Proposition 65 Warning

Battery posts, terminals, and related  
accessories contain lead and lead  
compounds, chemicals known to the  
State of California to cause cancer and  
reproductive harm.  
Wash hand after handling

**YANMAR**  
**MARINE DIESEL ENGINE**  
**MODELS : 6LYA-STP, 6LY2A-STP**  
**OPERATION MANUAL**

Thank you for purchasing the YANMAR Marine Diesel Engine.

## [INTRODUCTION]

- This Operation Manual describes the operation, maintenance and inspection of the **6LYA-STP, 6LY2A-STP** Yanmar marine diesel engines.
- Read this Operation Manual carefully before operate the engine to ensure that the engine is used correctly and that it stays in the best possible condition.
- Keep this Operation Manual in a convenient place for easy access.
- If this Operation Manual is lost or damaged, order a new one from your dealer or distributor.
- Make sure this manual is transferred to subsequent owners. This manual should be considered a permanent part of the engine and remain it.
- Constant efforts are made to improve the quality and performance of Yanmar products, so some details included in this Operation Manual may differ slightly from your engine. If you have any questions about such difference, please contact your Yanmar Dealer or Distributor.
- For detailed information marine gears other than model KMH6A/KMH6A1, refer to the Marine Gear Operation Manual.

|                                     |          |                            |
|-------------------------------------|----------|----------------------------|
| Operation Manual<br>(Marine Engine) | Models   | <b>6LYA-STP, 6LY2A-STP</b> |
|                                     | Code No. | 49961-205581               |

|  |              |
|--|--------------|
| <b>INTRODUCTION</b> .....  | <b>1</b>     |
| <b>INDEX</b> .....   | <b>2</b>     |
| <b>1. FOR SAFE OPERATION</b> .....   | <b>3~6</b>   |
| 1.1 Warning Symbols .....  | 3            |
| 1.2 Safety Precautions .....   | 4~5          |
| 1.3 Location of product safety Labels .....                                      | 6            |
| <b>2. EXPLANATION OF PRODUCT</b> .....   | <b>7~16</b>  |
| 2.1 Use, Driving System etc. ....  | 7            |
| 2.2 Engine Specifications .....  | 8            |
| 2.3 Names of Parts .....   | 9            |
| 2.4 Major Servicing Parts .....  | 10           |
| 2.5 Control Equipment .....  | 11~17        |
| 2.5.1 Control panel .....  | 11~15        |
| 2.5.2 Remote Control Handle .....  | 16           |
| <b>3. OPERATION</b> .....  | <b>17~32</b> |
| 3.1 Fuel oil, Lube oil & Cooling Water .....                                     | 17~19        |
| 3.1.1 Fuel .....   | 17           |
| 3.1.2 Lube oil .....   | 18           |
| 3.1.3 Cooling Water .....  | 18~19        |
| 3.2 Before Initial Operation .....   | 20~24        |
| 3.2.1 Supplying Fuel and Bleeding Air in the Fuel System .....                   | 20           |
| 3.2.2 Supplying Engine Lube oil .....  | 21           |
| 3.2.3 Supplying lube oil to marine gear (for Yanmar model : KMH6A KMH6A 1) ..... | 22           |
| 3.2.4 Supplying Cooling Water .....  | 22~23        |
| 3.2.5 Starting after storage or new engine .....                                 | 23           |
| 3.2.6 Checking and Resupplying Lube Oil and Cooling Water .....                  | 24           |
| 3.3 How to Operate .....   | 25~30        |
| 3.3.1 Inspection before Starting .....   | 25~27        |
| 3.3.2 How to Start the Engine .....  | 27~28        |
| 3.3.3 Shifting .....   | 29           |
| 3.3.4 Checking during Operation .....  | 29~30        |
| 3.3.5 Stopping the Engine .....  | 30           |
| 3.4 Long Term Storage .....  | 31~32        |
| <b>4. MAINTENANCE &amp; INSPECTION</b> .....                                     | <b>33~45</b> |
| 4.1 General Inspection Rules .....   | 33           |
| 4.2 Periodic Inspection .....  | 34~35        |
| 4.3 Periodic Inspection Items .....  | 36~45        |
| 4.3.1 Inspection after Initial 50 Hrs. Operation .....                           | 36~37        |
| 4.3.2 Inspection Every 50 Hours .....  | 37~38        |
| 4.3.3 Inspection after First 250 Hrs. ....                                       | 39           |
| 4.3.4 Inspection Every 250 Hrs. (or 1 yr.) .....                                 | 39~43        |
| 4.3.5 Inspection Every 500 Hrs. (or 2 yrs.) .....                                | 43           |
| 4.3.6 Inspection Every 1000 Hrs. (or 4 yrs.) .....                               | 43~44        |
| 4.3.7 Inspection Every 2000 Hrs. ....  | 44~45        |
| <b>5. TROUBLESHOOTING</b> .....  | <b>46~47</b> |
| <b>6. SYSTEM DIAGRAMS</b> .....  | <b>48~51</b> |
| 6.1 Piping diagram .....   | 48           |
| 6.2 Wiring diagram .....   | 49~51        |

# 1. FOR SAFE OPERATION

Following the precautions described in this manual will enable you to use this engine with complete satisfaction. Failure to observe any of the rules and precautions, however, may result in injury, burns, fires, and engine damage. Read this manual carefully and be sure you fully understand it before beginning operation.

## 1.1 Warning Symbols

These are the warning signs which are used in this manual and on the products. Pay special attention to them.



**DANGER**

**DANGER-** Indicates an imminently hazardous situation which, if not avoided, **WILL** result in death or serious injury.



**WARNING**

**WARNING-** Indicates a potentially hazardous situation which, if not avoided, **COULD** result in death or serious injury.



**CAUTION**

**CAUTION-** Indicates a potentially hazardous situation which, if not avoided, **MAY** result in minor or moderate injury. It may also be used to alert against unsafe practices.

- The descriptions captioned by **[NOTICE]** are for the particularly important cautions for handling. If you ignore them, the performance of your machine may deteriorate leading to trouble.

## 1.2 Safety Precautions

(Observe these instructions for your own safety.)

### ■ Precautions for Operation

**▲ DANGER**



#### Burns from Scalding

- Never remove the filler cap of the fresh water cooler while the engine is still hot. Steam and hot water will spurt out and seriously burn you. Wait until the water temperature has dropped, then wrap a cloth around the cap and loosen it slowly.
- After inspection, refasten the filler cap firmly. If the cap is not secure, steam or scalding water may be emitted during operation causing burns.

**▲ DANGER**



#### Proper Ventilation of the Battery Area

- Be sure the area around the battery is well-ventilated and there is nothing which could start a fire. During operation and charging, hydrogen gas is emitted from the battery and can be easily ignited.

**▲ DANGER**

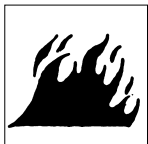

#### Fires from Oil Ignition

- Be sure to use the correct type of fuel when refueling. Mistakenly filling with gasoline or the like will result in ignition.
- Be sure to stop the engine before refueling. If you spill fuel, wipe such spillage carefully.
- Never place oils or other flammable material close to the engine as this could result in ignition.

**▲ WARNING**



#### Exhaust Gas Poisoning

- Be sure to establish good ventilation in the engine room with windows, vents, or other ventilation equipment. Check again during operation to be sure that ventilation is good. Exhaust gas contains poisonous carbon monoxide and should not be inhaled.

**▲ WARNING**



#### Moving Parts

- Do not touch the moving parts of the engine (propeller shaft, V-belt, PTO-pulley, etc.) during operation or let your clothing get caught in them as this can result in injury.
- Never operate the engine without the covers on the moving parts.
- Check before starting the engine to see that any tools or cloths used in maintenance have been removed from the area.

**▲ CAUTION**



#### Burns from Contact with Hot Engine Parts

- The whole engine is hot during operation and immediately after stopping. The turbocharger, exhaust manifold, exhaust pipe, and engine are very hot. Never touch these parts with your body or clothing.



## Alcohol

- Never operate the engine while you are under the influence of alcohol or when you are ill or feel unwell as this results in accidents.

## ■ Safety Precautions for Inspection



### Battery Fluid



- Battery fluid is diluted sulfuric acid. It can blind you if it gets in your eyes, or burn your skin. Keep the fluid away from your body. Wash it off immediately with a large quantity of fresh water if you get any on you.



### Fire due to Electric Short-Circuits



- Always turn off the battery switch or detach the earth cable (-) before inspecting the electrical system. Failure to do so could cause short-circuiting and fires.



### Precautions for Moving Parts



- Stop the engine before you service it. If you must inspect while the engine is operating, never touch moving parts. Keep your body and clothing well clear of all moving parts as this could result in injury.



### Precautions for Removing Hot Oil and Water to Prevent Burns



- If extracting oil from the engine while it is still hot, do not let the oil splash on you.
- Wait until the temperature has dropped before removing cooling water from the engine to avoid getting scalded.

#### [NOTICE]

### Do not alter the diesel engine.

Rebuilding the engine or altering parts to increase the speed or the amount of fuel discharged, etc. will make operation unsafe, and result in damage and shortening of engine life.

#### [NOTICE]

### Disposal of waste materials

- Put oil or liquids to be disposed in a container. Never dispose of waste oil or other fluids outside, in a sewer, river, or the sea.
- Treat waste materials safely observing all regulations and laws. Ask a waste recovery company to collect and dispose of it.

# 1.3 Location of Product Safety Labels

To insure safe operation, warning device labels have been attached. Their location is shown in the diagram below. Keep the labels from becoming dirty or torn and replace them if they are lost or damaged. Also, replace labels when parts are replaced, ordering them in the same way as for the parts.

## Warning Device Labels, Parts Numbers

| No. | Part Code No. |
|-----|---------------|
| ①   | 128296-07300  |
| ②   | 120324-07240  |
| ③   | 128296-07260  |
| ④   | 128296-07350  |

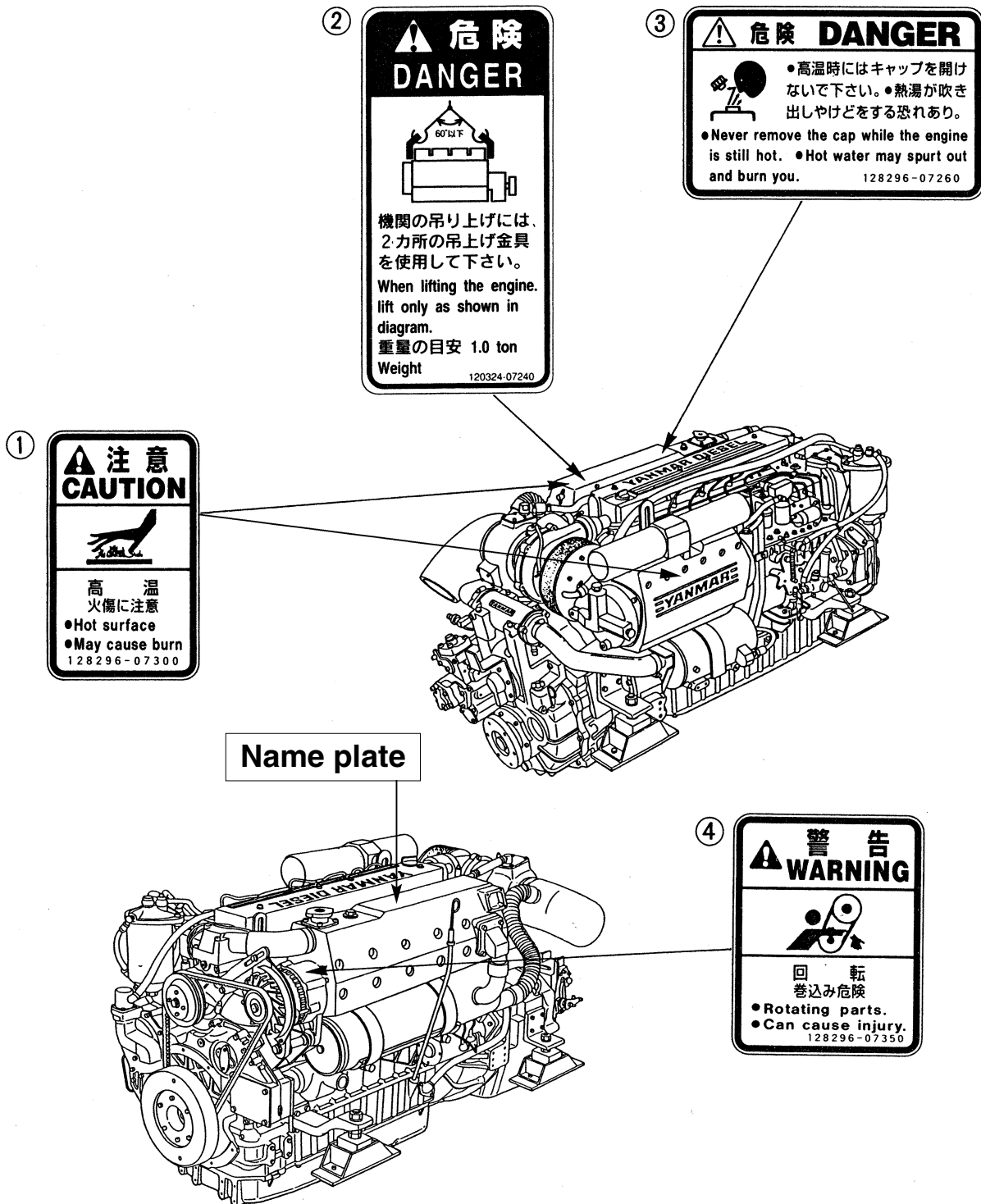



## 2. Explanation of Product

### 2.1 Use, Driving System, etc.

In the case of engine with marine gear, connect the propeller shaft to the marine gear output shaft.

In order to obtain full performance from your engine, it is imperative that you check the size and structure of the hull and use a propeller of the appropriate size.

The engine must be installed correctly with safe cooling water and exhaust piping and electrical wiring.

To handle the drive equipment, driven systems (including the propeller) and other onboard equipment, be sure to observe the instructions and cautions given in the operation manuals supplied by the shipyard and equipment manufacturers.

The laws of some countries may require hull and engine inspections, depending on the use, size and cruising area of the boat.

The installation, fitting and surveying of this engine all require specialized knowledge and engineering skills.

Consult Yanmar's local subsidiary in your region or your distributor or dealer.

#### WARNING

Never modify this product or release the limit devices (which limit engine speed, fuel injection quantity, etc.). Modification will impair the safety and performance of the product and functions and shorten the product life.

Please note that any troubles arising from modification of the product will not be covered by our warranty.

## 2.2 Engine Specifications

|   |   |   |   |   |
|---|---|---|---|---|
| Engine model                              | 6LYA-STP                                      |   | 6LY2A-STP                                       |   |
| Type                                      | Vertical water cooled 4-cycle diesel engine   |   |   |   |
| No. of cylinders                          | 6   |   |   |   |
| Bore × Stroke                             | mm  | 100×110                                 |   | 105.9×110                               |
| Displacement                              | ℓ   | 5.184                                   |   | 5.813                                   |
| Fuel stop power at crankshaft             | kw(hp)/rpm                                    | *272 (370) / 3300<br>**264 (359) / 3300 |   | *324 (440) / 3300<br>**315 (427) / 3300 |
| Cont. power at crankshaft.                | kw(hp)/rpm                                    | 213 (290) / 3100                        |   | 257 (350) / 3100                        |
| High idling                               | rpm   | 3720±25                                 |   | 3670±25                                 |
| Low idling                                | rpm   | 700±25                                  |   |   |
| Combustion system                         | Direct injection                              |   |   |   |
| Starting system                           | Electric starting                             |   |   |   |
| Cooling system                            | Fresh water cooling                           |   |   |   |
| Lubrication system                        | Forced lubrication system with gear pump      |   |   |   |
| Direction of rotation (crankshaft)        | Counter clockwise (viewed from flywheel side) |   |   |   |
| Lube oil capacity                         | All   | ℓ                                       | 20  |   |
|   | Oil pan                                       | ℓ                                       | 18(including oil filter capacity)(oil pan 16.4) |   |
| Cooling water capacity                    | ℓ   | Engine:20, Subtank :1.5                 |   |   |
| Turbochager                               | Model   | RHC7W (IHI made)                        |   |   |
|   | Type  | Water cooled turbine housing            |   |   |
| Dry mass(gear less)                       | kg  | 530                                     |   | 535                                     |
| Recommended battery capacity              | 12V×120Ah                                     |   |   |   |
| Recommended type of remote control handle | Single lever type                             |   |   |   |
| Engine installation style                 | On the flexible engine mount                  |   |   |   |

(Note) 1. Rating condition : ISO 3046-1, 8665 2. 1hp = 0.7355 kW  
 3. Fuel condition : Density at 15°C = 0.860, Fuel oil temperature \*: 25°C at the fuel injection pump inlet  
 \*\*: ISO 8665 (Fuel oil temp. 40°C at the fuel injection pump inlet)

### ● Marine gear (Option)

#### ● For 6LYA-STP

|                   |                    |      |      |          |     |     |                             |     |           |     |     |      |     |
|-------------------|--------------------|------|------|----------|-----|-----|-----------------------------|-----|-----------|-----|-----|------|-----|
| Model             | KMH6A              |      |      | HSW800A2 |     |     |                             |     | MG5050A   |     |     |      |     |
| Type              | 10° Angle          |      |      | 8° Angle |     |     |                             |     | 10° Angle |     |     |      |     |
|                   | wet and multi-disc |      |      |          |     |     |                             |     |           |     |     |      |     |
| Reduction ratio   | 1.58               | 1.92 | 2.26 | 1.2      | 1.4 | 1.6 | 2.0                         | 2.5 | 1.12      | 1.5 | 1.8 | 2.04 | 2.5 |
| Lube oil capacity | Full               | ℓ    |      | 4.0      |     |     | Refer to the maker's manual |     |           |     |     |      |     |
|                   | Effective          | ℓ    |      | 0.3      |     |     |                             |     |           |     |     |      |     |

#### ● For 6LY2A-STP

|                   |                    |      |      |          |      |      |                             |      |
|-------------------|--------------------|------|------|----------|------|------|-----------------------------|------|
| Model             | KMH6A1             |      |      | MG5061A  |      |      |                             |      |
| Type              | 10° Angle          |      |      | 7° Angle |      |      |                             |      |
|                   | wet and multi-disc |      |      |          |      |      |                             |      |
| Reduction ratio   | 1.58               | 1.92 | 2.26 | 1.13     | 1.54 | 1.75 | 2.00                        | 2.47 |
| Lube oil capacity | Full               | ℓ    |      | 4.0      |      |      | Refer to the maker's manual |      |
|                   | Effective          | ℓ    |      | 0.3      |      |      |                             |      |

(Note)  
 Reduction ratio:  
 Both ahead and astern

## 2.3 NAMES OF PARTS

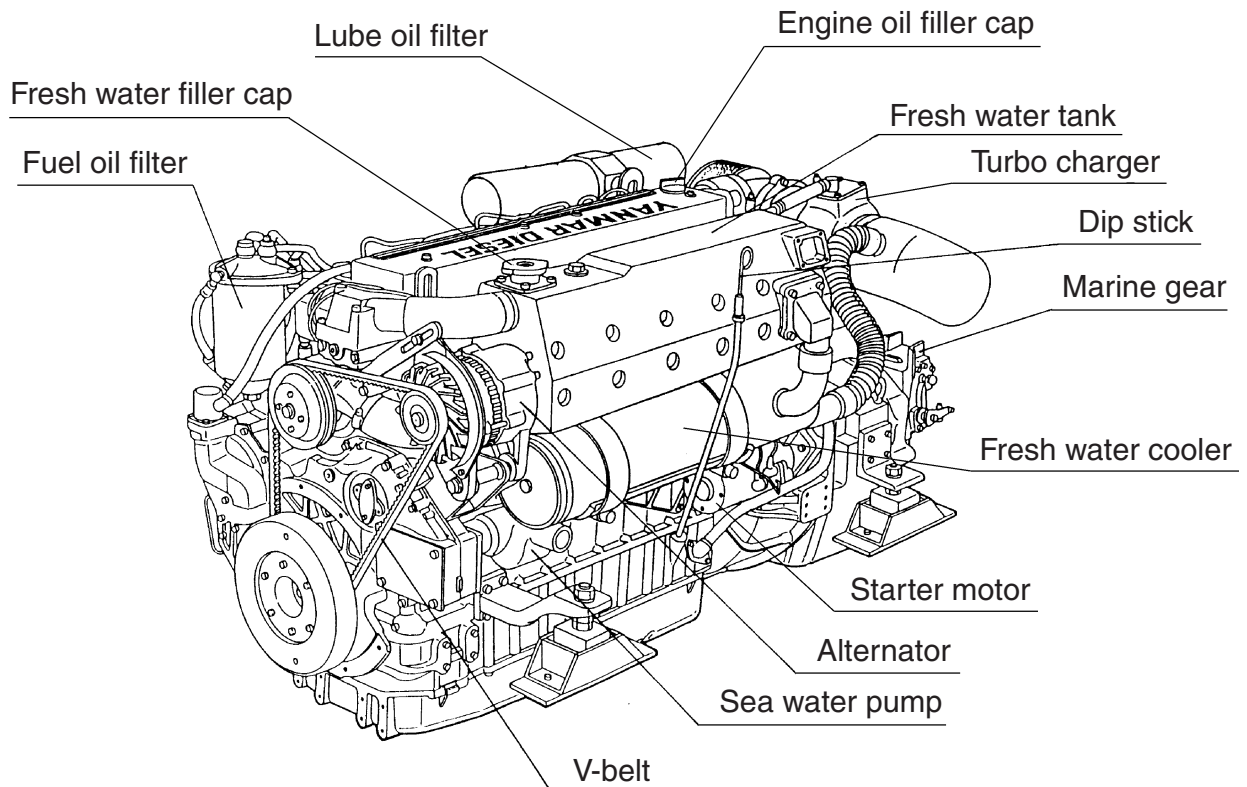
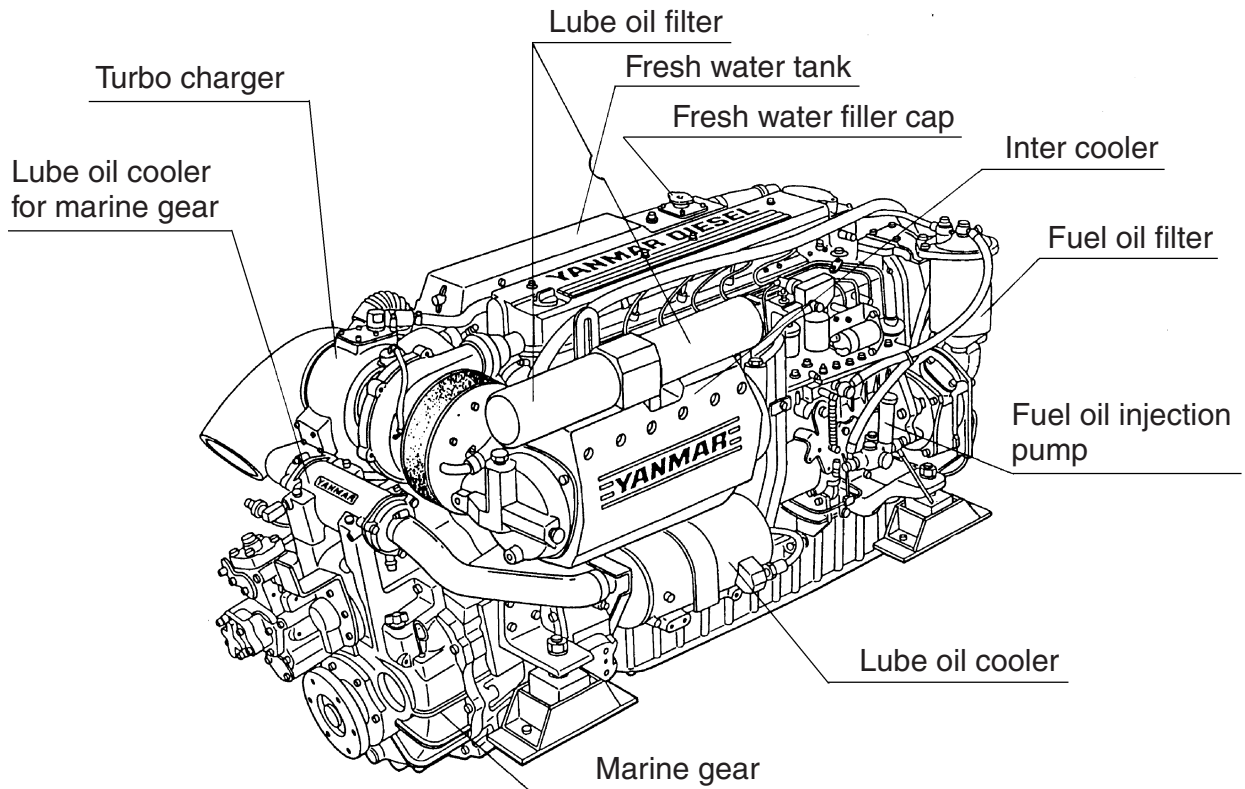

<Note> This illustration shows Yanmar marine gear (Model : KMH6A) when it has been attached.

## 2.4 Major Servicing Parts

| Name of Part                                       | Function  |
|--|---|
| ● Fuel filter                                      | Removes dust and water from fuel. Drain the filter periodically, (there is a drain plug at the bottom). The internal element (filter) should be changed periodically.   |
| ● Fuel feed pump                                   | Feeds fuel to the fuel injection pump.<br>Equipped with mechanical pump attached with the fuel injection pump.  |
| ● Engine oil filler cap                            | Filler port for engine lube oil.  |
| ● Lube oil filters<br>(Full-flow & by-pass)        | Filters fine metal fragments and carbon from the lube oil.<br>The oil through the full flow filter is sent to the engine's moving parts and another ones through the by-pass filter returns to oil pan.   |
| [Cooling Water System]                             | This engine has two cooling water systems (for fresh water & for seawater).<br>Fresh water flows from the fresh water tank into the fresh water cooler, where the fresh water is cooled by sea water.<br>The fresh water then flows into the cylinder block through the fresh water pump. It further cools the turbocharger and goes back to the fresh water tank.  |
| ● Fresh water cooler<br>○ Filler cap<br>○ Sub tank | The fresh water cooler is a heat exchanger using sea water.<br>The filler cap mounted on the fresh water tank has a pressure regulating valve.<br>When the cooling water temp. rises and then the pressure rises inside the fresh water tank, the pressure regulating valve releases vapor and hot water overflow to the sub tank.  |
| ○ Rubber hose                                      | The hose is connected between the filler cap and sub tank. Vapor and hot water discharged to the sub tank.<br>When the engine stops and cooling water cools, the pressure in the cooling water tank also drops to negative pressure. The filler cap valve then opens to suck water back from the sub tank. This minimizes cooling water consumption.  |
| ● Fresh water pump                                 | The centrifugal water pump circulates fresh cooling water inside the engine.<br>The pump is driven by the V-belt.   |
| ● Seawater pump                                    | The rubber impeller-type pump is driven by gears. Do not operate it without seawater, due to damage the impeller.   |
| ● Oil cooler                                       | This heat exchanger cools high temp. engine oil by seawater.  |
| ● Turbocharger                                     | The pressurized intake air feeding device: the exhaust gas turbine is rotated by the exhaust gas, and the power is used to rotate the blower. This pressurizes the intake air for sending to the cylinder.  |
| ● Inter-cooler                                     | This heat exchanger cools the pressurized intake air from the turbocharger with seawater.   |
| ● Anticorrosive zinc                               | The metal area of the seawater cooling system is prone to electrical corrosion. The anti-corrosive zinc is installed in the oil cooler, inter-cooler, etc. to prevent this.<br>The anti-corrosive zinc is itself reduced over time by electrical corrosion, so it must be replaced at fixed intervals before it is completely consumed in order to ensure that the metal area of the seawater cooling system remains fully protected. |
| ● Name plate                                       | Name plates are provided on the engine and have the model, serial number and other data.  |
| ● Starter  | Starter powered by the battery.   |
| ● Alternator                                       | Rotates by belt drive, generates electricity and charges the battery.   |

## 2.5 Control Equipment

The control equipment consists of the control panel and remote control handle, which are connected by the wires and cables to the control levers for remote control operation.

### 2.5.1 Control Panel (Optional)

The control panel has the following gauges and alarm devices (optional accessories):

| No. | Model           |                                | New B-type      | New C-type      | New D-type |
|-----|-----------------|--------------------------------|-----------------|-----------------|------------|
| 7   | Switch unit     | Key switch (Starter switch)    | ●               | ●               | ●          |
| 8   |                 | Engine stop switch             | ●               | ●               | ●          |
| 10  |                 | Alarm buzzer                   | ●               | ●               | ●          |
| 9   |                 | Alarm buzzer stop switch       | ●               | ●               | ●          |
| 11  |                 | Illumination switch for meters | ●               | ●               | ●          |
| 6   | Alarm lamp unit | Battery not charging           | ●               | ●               | ●          |
|     |                 | C.W. high temperature          | ●               | ●               | ●          |
|     |                 | L.O. low pressure (engine)     | ●               | ●               | ●          |
|     |                 | C.W level                      | ●               | ●               | ●          |
|     |                 | Exhaust                        | ●               | ●               | ●          |
|     |                 | Boost                          | —               | ●               | ●          |
| 1   | Tachometer unit | Tachometer with hour meter     | ●               | ●               | ●          |
| 4   | Sub meter unit  | LO. pressure meter             | —               | ●               | ●          |
| 3   |                 | C.W. temperature meter         | —               | ●               | ●          |
| 5   |                 | Boost meter (Turbo)            | —               | —               | ●          |
| 12  | Clock unit      | Quartz clock                   | ●<br>(optional) | ●<br>(optional) | ●          |

● Available, — Not available

#### ● New B-type

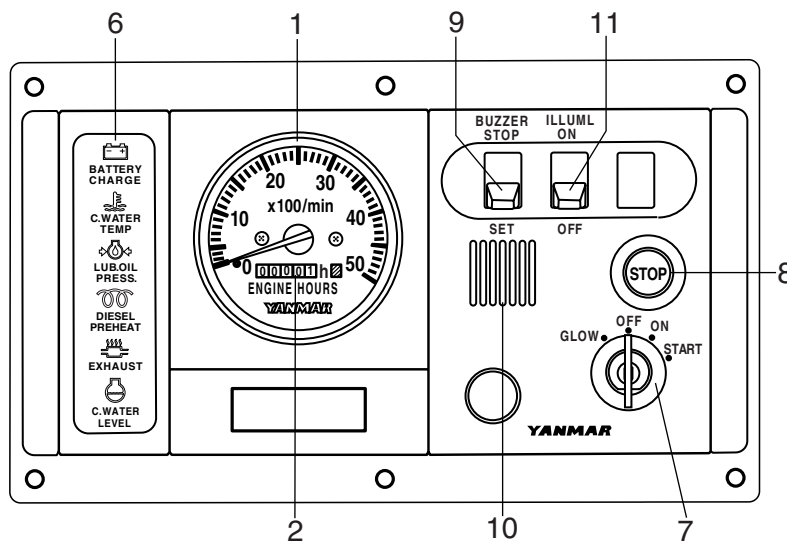

● New C-type

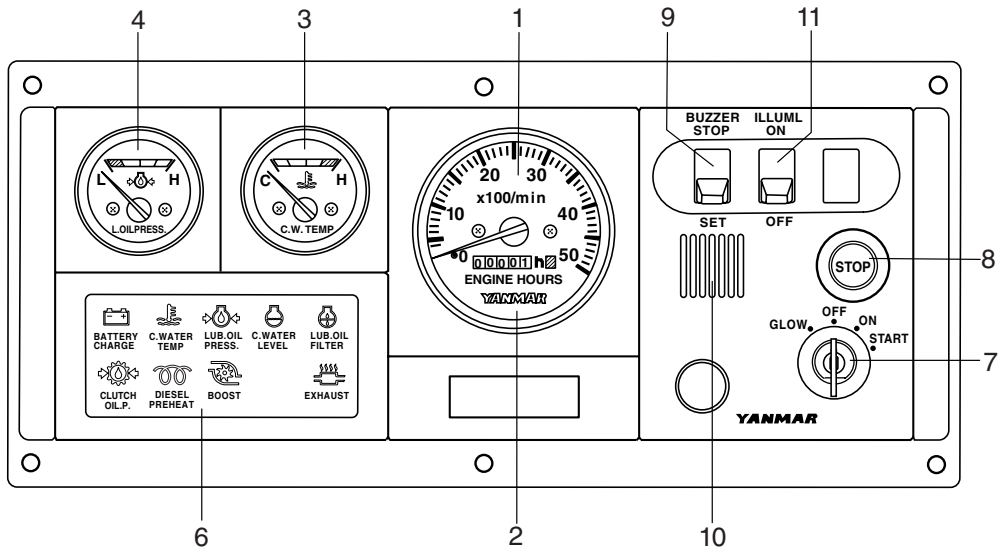

● New D-type

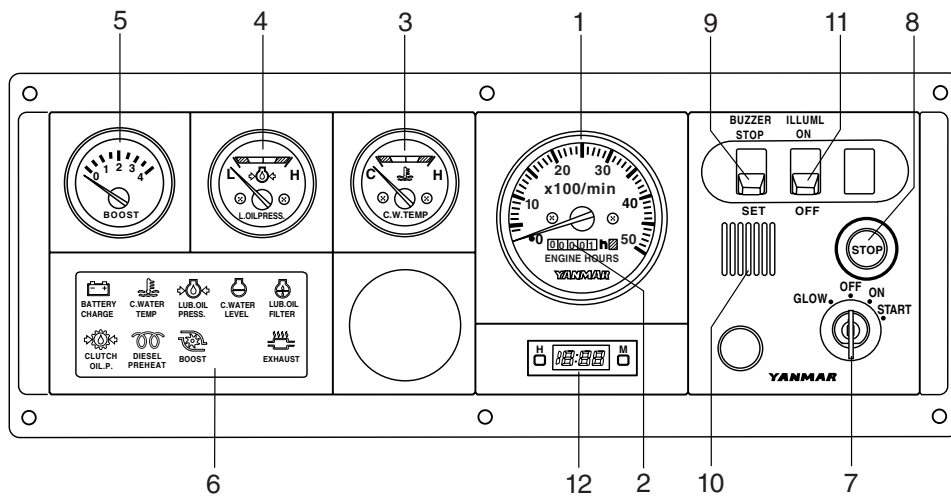



● Available switches (for alarm) and senders (for meter) (attached with engine)

|          |                      | 6LYA-STP         | 6LY2A-STP |   |
|----------|----------------------|------------------|-----------|---|
| Switches | Battery not charge   | ○                | ○         |   |
|          | C.W.high temperature | ○                | ○         |   |
|          | L.O low pressure     | ○                | ○         |   |
|          | C.W.level            | ×                | △         |   |
|          | Exhaust (C.S.W flow) | ×                | △         |   |
|          | Boost                | ×                | △         |   |
| Senders  | Tachometer           | ○                | ○         |   |
|          | C.W. temperature     | △                | △         |   |
|          | L.O.pressure         | △                | △         |   |
|          | Boost                | △                | △         |   |
|          | C.W.temp.            | For two stations | △         | △ |
|          | L.O. press.          |                  | △         | △ |

○ : Standard   △ : Optional   × : Not available

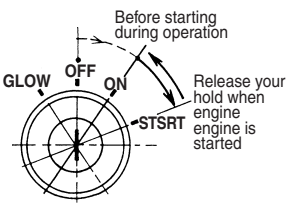
## (1) Gauges and Equipment

| Gauges & Equipment  | Functions  |
|---|--|
| <p>Starter switch</p>                            | <p>OFF: The switch key can be inserted or removed.<br/>All power is turned off.</p> <p>ON: For engine operation. Gauges and alarm devices are turned on.</p> <p>START: For engine starting. When the key is released after starting, it moves automatically to ON.</p> <p>GLOW: For the air heater (optional)</p> <p><b>(Note)</b> ● The engine cannot be stopped by the starter switch.</p> |
| <p>Engine stop switch</p>   | <p>Press the button to stop the engine by fuel cut.<br/>And continue to push the stop button until the engine has come to a complete stop.</p>   |
| <p>Alarm buzzer</p>   | <p>The buzzer sounds if an abnormality arises.<br/>See explanation under (2).</p>  |
| <p>Warning lamps</p>  | <p>The lamps come on when an abnormality arises.<br/>See explanation under (2).</p>  |
| <p>Buzzer stop switch</p>   | <p>The switch is used to stop the buzzer noise temporarily. Do not turn the buzzer off except when inspecting for an abnormality.</p>  |
| <p>Illumination switch</p>  | <p>Switch for lighting control panel.</p>  |
| <p>Hour meter</p>   | <p>Total operation hours are shown in the window below the tachometer.<br/>Refer to the figure as a standard for periodic inspections.</p>   |
| <p>Lube.Oil. pressure meter</p>   | <p>The needle shows engine oil pressure.</p>   |
| <p>Cooling water temperature meter</p>  | <p>The needle shows engine cooling fresh water temperature.</p>  |
| <p>Boost meter</p>  | <p>The needle shows intake air pressure (intake air boost pressure of turbocharger.)</p>   |
| <p>Heat up indicating lamp for air heater</p>  | <p>The lamp comes on when the air heater is heated up to start the engine easily under low temperature condition. (Refer to 3.3.2(3))<br/>(The lamp is located in warning lamp display column.)</p>  |

## (2) Functions of Alarm Devices (Alarm Buzzer & Lamps)

- 1) The alarm buzzer sounds when any warning lamp (except the charge lamp) comes on.
- 2) Warning lamps come on when sensors (switches) detect an abnormality during engine operation. The warning lamps in the display column of the control panel are off during normal operation, but come on as follows when an abnormality arises:

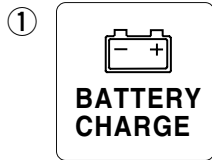

### Charge Lamp

The lamp comes on when there is a charging failure. The alarm buzzer does not sound. Check for breakage in the alternator V-belt

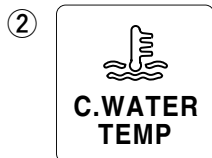

### Cooling Water Temp. Warning Lamp

The lamp comes on when the cooling water (LLC) gets too hot. Check the water level in the sub-tank and cooling water tank, and the discharge volume of the cooling seawater.



### Lube Oil Pressure Warning Lamp

The lamp comes on when the engine lube oil pressure drops. Check the engine oil level.



### Cooling Water Level Warning Lamp.

The lamp comes on when the cooling water (LLC) in the cooling water tank falls below the normal level. Check the cooling water level in the cooling water tank.



### Exhaust : Cooling seawater Discharg Warning Lamp.

The lamp comes on when the cooling seawater flow becomes too small. Check for clogging in the seawater cooling system.



### Boost Pressure Warning Lamp

The lamp comes on when the intake air boost pressure (intake air boost pressure of turbocharger) rises abnormally.

## (3) Functions of Warning Devices

When the key switch is turned on, the alarm devices function as follows

- 1) Turning the key to ON :
  - ① Warning buzzer sounds
  - ② The BATTERY CHARGE, LUB. OIL PRESS. and EXHAUST lamps come on.  
**(Note)** When the warning buzzer and lamps function as above, everything is normal.
- 2) When the key switch is turned to START to start the engine and then returned to ON after the engine starting up.
  - ① The warning buzzer stops sounding.
  - ② All warning lamps go off. After the engine starts up, make it the rule to check alarm devices. If they do not work normally, contact your dealer.



| Function of Alarm Devices |                               |                                |
|---------------------------|-------------------------------|--------------------------------|
| Key Operation             | Before starting<br>OFF<br>→ON | After Starting<br>START<br>→ON |
| Alarm Buzzer              | <b>On</b>                     | <b>Off</b>                     |
| Alarm Lamps               |                               |                                |
| Charge Lamp               | <b>On</b>                     | <b>Off</b>                     |
| Cooling Water Temperature | <b>Off</b>                    | <b>Off</b>                     |
| Engine Oil Pressure       | <b>On</b>                     | <b>Off</b>                     |
| Cooling Water Level       | <b>Off</b>                    | <b>Off</b>                     |
| Exhaust                   | <b>On</b>                     | <b>Off</b>                     |
| Boost                     | <b>Off</b>                    | <b>Off</b>                     |

## 2.5.2 Remote Control Handle

Use the remote control handle in the steering room for ahead, astern and speed control.

### ● Operation of Single Lever Remote Control Handle (Option)

- ① : The marine gear shift lever is in neutral.
- ② : The marine gear shift lever is in ahead or astern
- ③ : Engine's max. speed position.
- ②~③ : Acceleration position

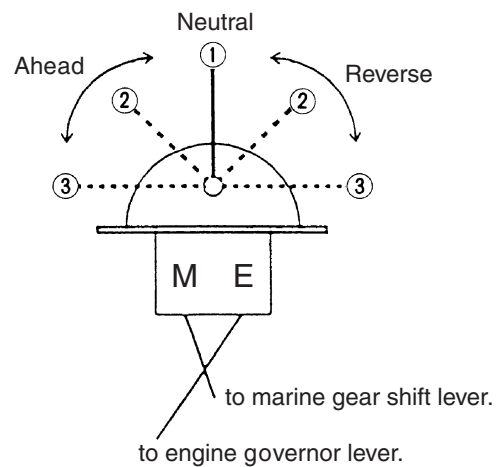
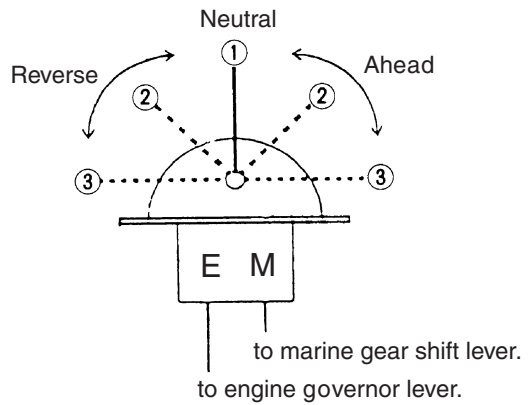
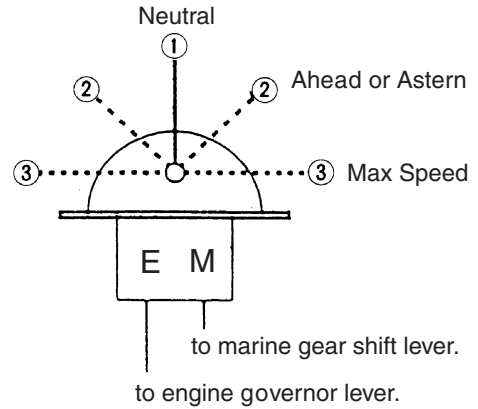
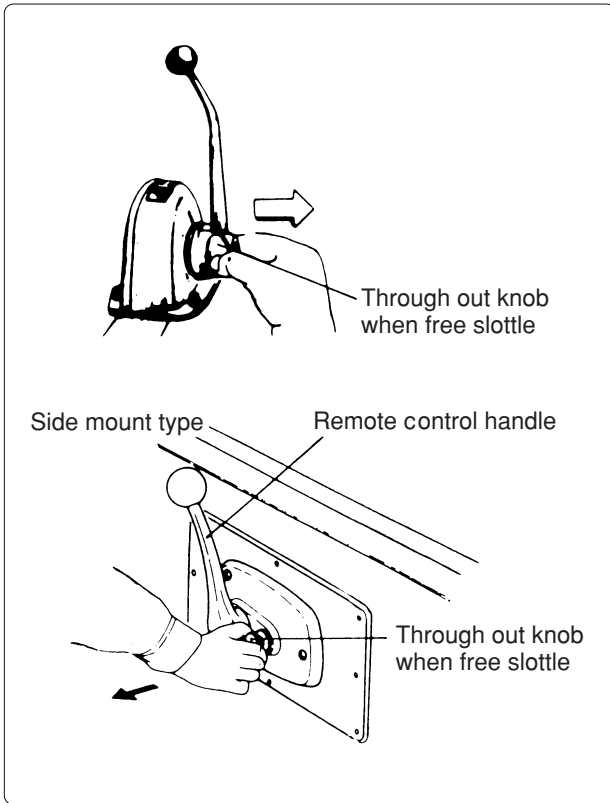

# 3. OPERATION

## 3.1 Fuel Oil, Lube Oil & Cooling Water

### 3.1.1 Fuel

**[NOTICE]**

Use of fuels not recommended in this Operation Manual may cause a decrease in engine performance and cause components to fail.

#### (1) Selection of fuel

Use the following diesel fuels for best engine performance:  
ISO8217 DMA, BS2869 A1 or A2

**Fuels equivalent to Japanese Industrial Standard, JIS. No. K2204-2**

Cetane fuel number should be 45 or greater

#### (2) Fuel Handling

- 1) Water and dust in the fuel oil can cause operation failure.  
Use containers which are clean inside to store fuel oil. Store the containers away from rain water and dust.
- 2) Before supplying fuel, let the fuel container rest for several hours so that water and dust in the fuel are deposited on the bottom. Pump up only the clean fuel.
- 3) Use fuel with a Cetane number of over 45.
- 4) When supplying fuel to a new boat for the first time, be sure to extract all fuel from the F. O. tank and check for impurities in the fuel.

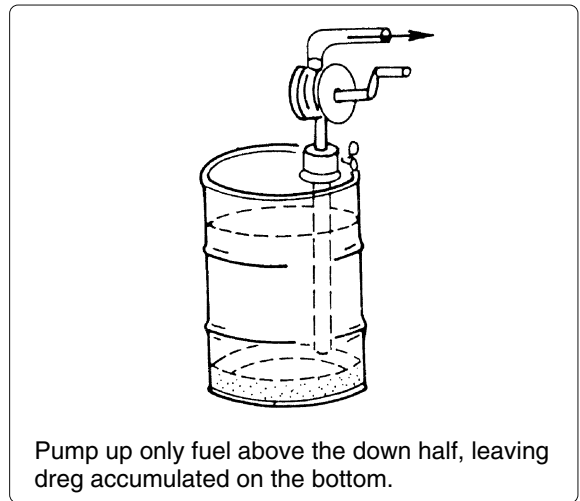

#### (3) Fuel piping

Install the piping between the fuel tank and the engine's fuel injection pump, as illustrated on the right.

Be sure to install a drain cock at the bottom of the fuel tank to remove water and dust.

Install an oil/water separator and a fuel filter in the middle of the fuel piping.

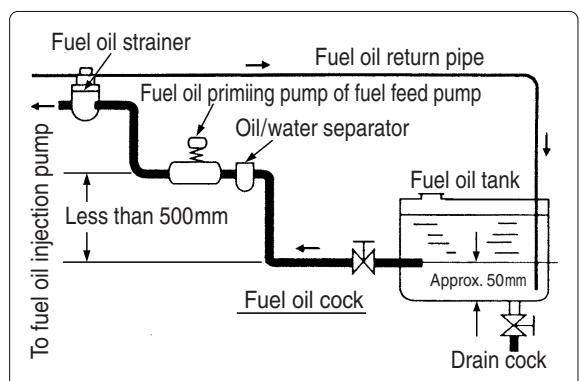

### 3.1.2 Lube oil

**[NOTICE]**

Use of lube oils not specified in this operation manual may cause the seizure or premature wear of internal parts and shorten the engine's life.

**(1) Selection of Engine Lube Oil**

Use the following lube oil:

- API CD SAE Viscosity ..... 30
- SAE Viscosity.....15W40

**(2) Selection of Oil for marine gear.**

- Yanmar KMH6A, KMH6A1...SAE Viscosity 30
- Follow the instructions for other types of Marine Gear.

**(3) Handling the Lube Oil**

- 1) When handling and storing lube oil, be careful not to allow dust and water to enter the lube oil. Clean around the filter port before refilling.
- 2) If lube oil of different brands are blended, the quality of lube oil may deteriorate. To prevent this, do not mix the lube oil.
- 3) Lube oil supplied to the engine will undergo natural degeneration with time even when the engine is not used.

Lube oil should be replaced at the specified intervals regardless of whether the engine is being used or not.

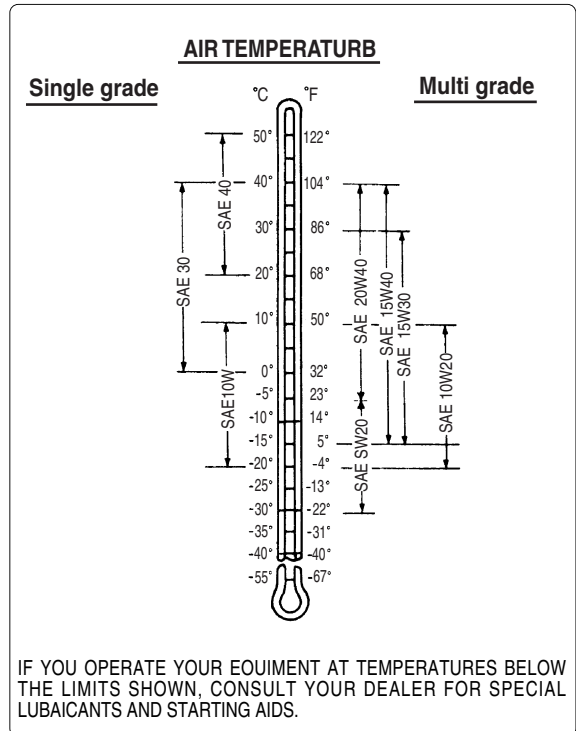

### 3.1.3 Cooling Water

**[NOTICE]**

**Be sure to add Long Life Coolant /Antifreeze (LLC) to cooling fresh water.**

**In cold seasons, the LLC is especially important.**

**Without LLC, cooling performance will decrease due to scale and rust in the cooling water line. Without LLC, cooling water will freeze and expand, breaking various parts.**

## (1) Handling of Cooling Water

1) Always use purified soft water or distilled water for the fresh water. Never use dirty water or hard water.

Impurities in the fresh water cause scale and rust to build up on the cooling water passage, reducing cooling efficiency and causing the engine to overheat.

2) Choose LLC which will not have any adverse effects on the materials (cast iron, aluminum, copper, etc.) of the engine's fresh water cooling system.

Consult your Yanmar dealer or distributor on the use of coolant/antifreeze, and detergents. The coolants/antifreezes, which are good performance for example, are shown below.

- TEXACO LONG LIFE COOLANT ANTIFREEZE, both standard and pre-mixed.

Product codes 7997 and 7998.

- HAVOLINE EXTENDED LIFE ANTIFREEZE/COOLANT.

Product code 7994.

3) Strictly use the proper mixing ratio of LLC to fresh water as instructed by the LLC maker. If incorrect ratio of LLC to fresh water is used, the cooling performance of the cooling water will drop and the engine may become overheated.

4) Do not mix different types (brand) of LLC, chemical reactions may make the LLC useless and engine trouble could result.

5) Replace the cooling water periodically according to the maintenance schedule given in this operation manual.

6) Remove the scale from the cooling water system periodically according to the instructions this operation manual.

### [NOTICE]

**Excessive use of LLC also lowers the cooling efficiency of the engine.**

**Be sure to use the mixing ratios specified by the LLC maker for your temperature range.**

## 3.2 Before Initial Operation

Prepare for initial operation according to the following procedures :

### 3.2.1 Supplying Fuel and Bleeding Air in the Fuel System.

#### **⚠ DANGER**



- Gasoline will catch fire!  
Check again before supplying that you are using the proper fuel.
- If any fuel is spilled, clean it off completely.

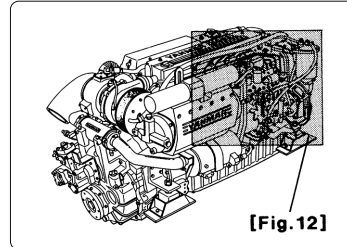

#### (1) Supplying Fuel

- 1) Before supplying fuel, flush the fuel tank and the fuel system parts with clean kerosene or diesel fuel.
- 2) Supply fuel with no dust and water to the fuel tank

#### (2) Bleeding Air in the Fuel System

Bleed air in the fuel system according to the following procedurs. When there is air in the fuel system, the fuel injection pump will not able to do the function.

- 1) Open the cock on the fuel oil inlet pipe line, and loosen the air bleeding bolt on the top of the water/fuel oil separator (optional) by turning 2~3 times using spanner. When fuel with no air bubbles come out, tighten the air bleeding bolt.
- 2) Loosen the priming pump knob turning counter-clockwise and repeatedly push the knob by hand to feed fuel oil to the fuel filter.
- 3) Loosen the ball joint bolt on the top of center of the fuel filter. And relese fuel from there until fuel with no air bubbles come out, then tighten the ball joint bolt.
- 4) Push down the priming pump knob and turn it clockwise to fasten.

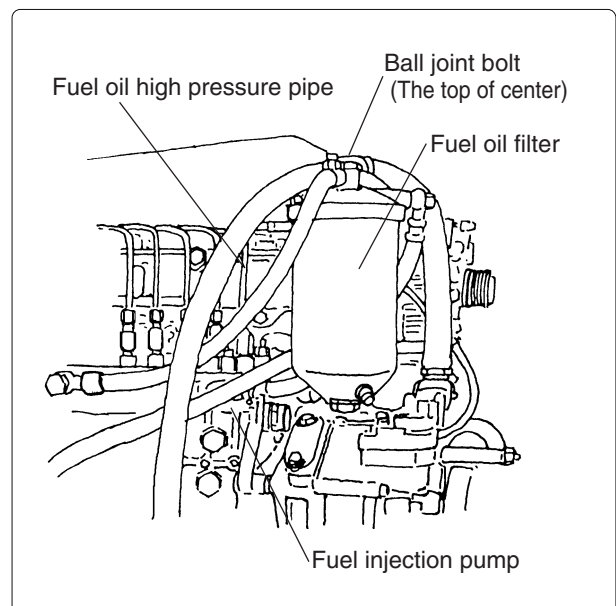
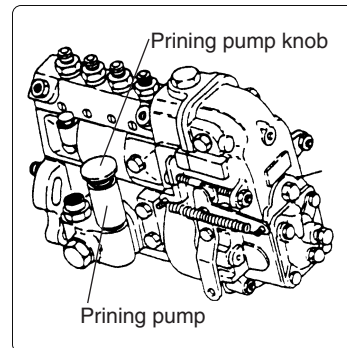

### 3.2.2 Supplying Engine Lube Oil

- 1) Remove the filler cap and supply the engine lube oil.
- 2) Supply lube oil up to the upper limit on the oil dipstick. To check the oil level, insert the dipstick in fully.

**Engine Lube Oil Capacity : All 20.0 ℓ**  
**(oil pan full 16.4 ℓ )**

- 3) Fasten the filler cap fully.

**[NOTICE]**

Never supply too much lube oil.  
 If overfilled, oil may come out from the breather and cause engine trouble.

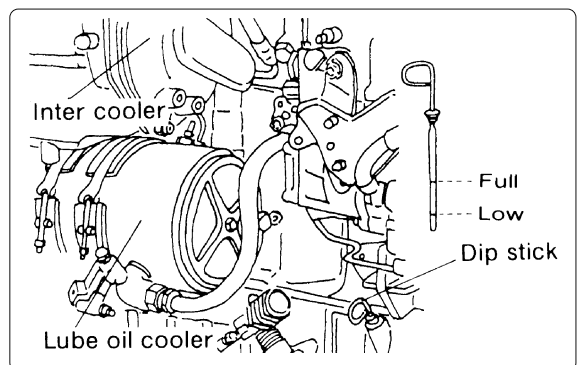
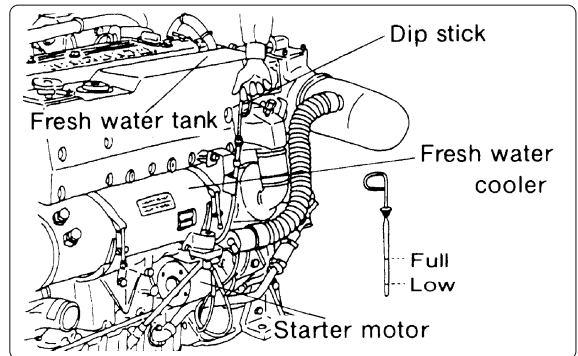
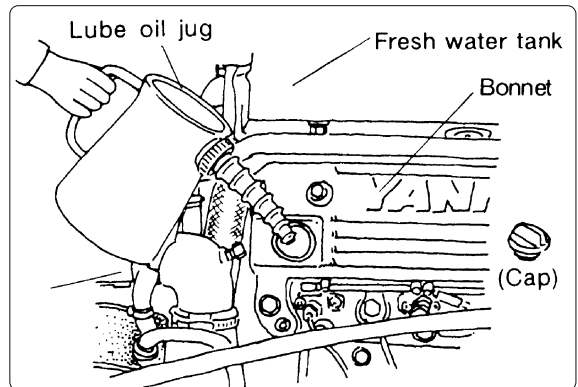
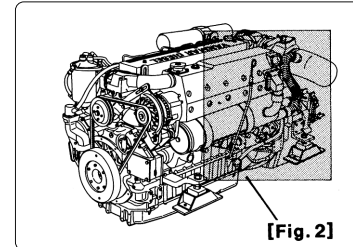
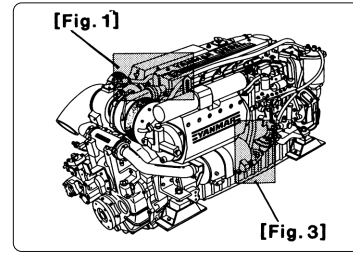

### 3.2.3 Supplying lube oil to marine gear

(for Yanmar model KMH6A, KMH6A1)

- 1) Remove the filler cap and supply the lube oil to the marine gear.
- 2) Supply lube oil up to the upper limit on the oil dipstick. To check the oil level, insert the dipstick in fully.

**Lube Oil Capacity : Full 4.0 ℓ**

- 3) Fasten the filter cap fully.

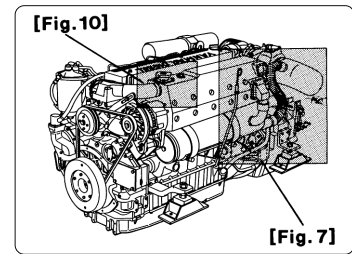
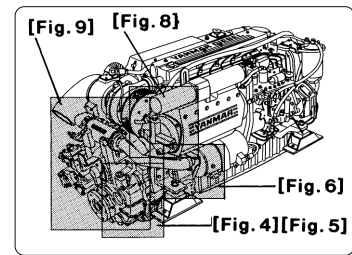

### 3.2.4 Supplying Cooling Water

Supply cooling water according to the following procedures. Be sure to add LLC to the fresh water.

- 1) Close the water drain cocks (Close both the fresh water line drain cocks and the sea water line drain cocks.)

**Number of drain Cock**

| Fresh water line | Sea water line |
|------------------|----------------|
| 2                | 4              |

**(Note) The water drain cocks are opened before shipping from the plant.**

- 2) Remove the filler cap of the fresh water tank. (Turn the filler cap by 1/3 turn counterclockwise to remove.)
- 3) Supply cooling water slowly to the fresh water tank so that no air bubbles will develop. Supply until the water overflows from the filler port.
- 4) After supplying cooling water, fasten the filler cap firmly. If loose, trouble will occur due to water leakage. To fasten, align the notch at the rear of the cap with the slot of the filler port and turn the cap by 1/3 turn.
- 5) Remove the cap of the sub-tank, supply water to the full limit and fasten the cap.

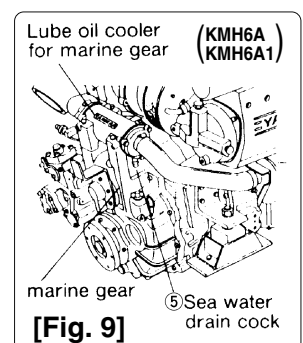
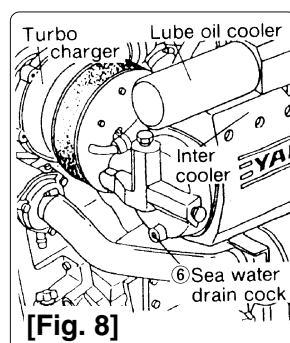
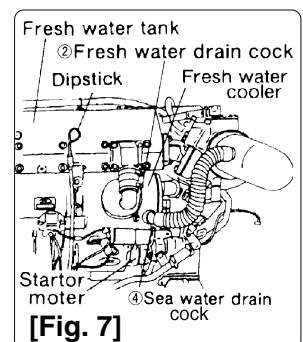
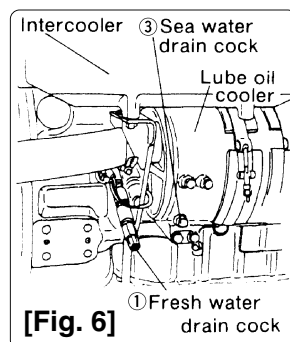
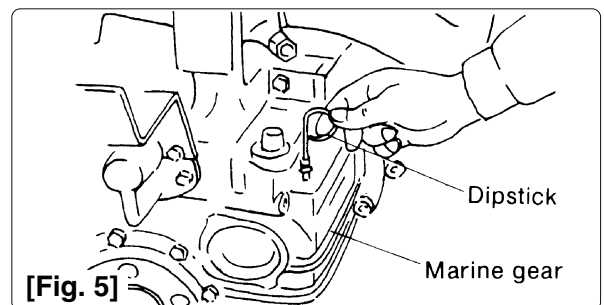
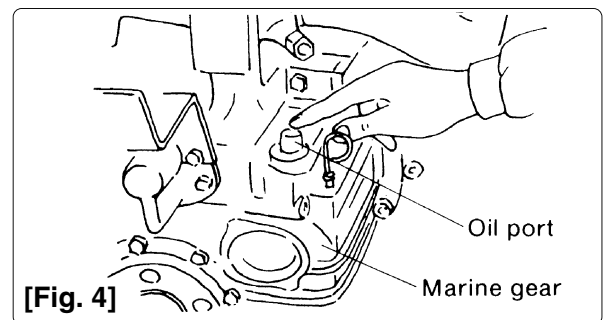



- 6) Check the rubber hose connecting the sub-tank with the fresh water tank. If the hose is not water-tight, a lot of cooling water will be consumed.

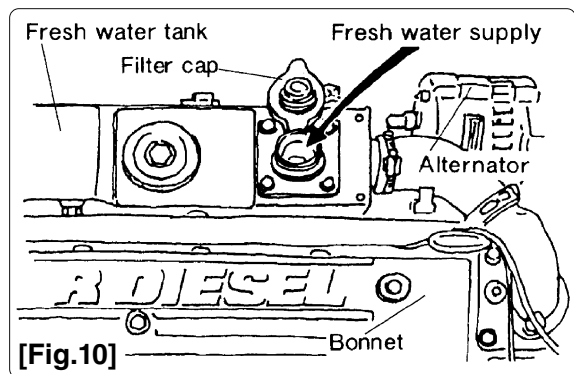
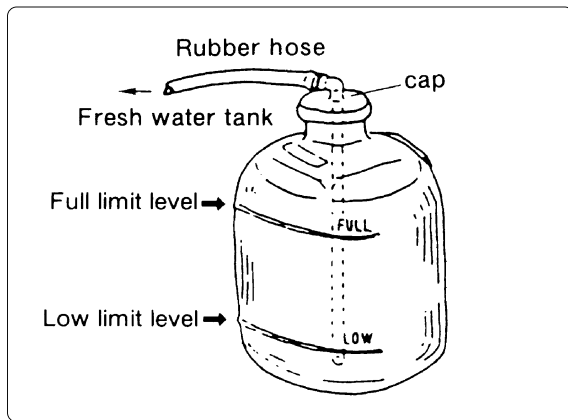

**⚠ DANGER**



If the filler cap is loose, hot steam and water will spout out and you may be burned.

### 3.2.5 Starting after storage or new engine

If the engine has not been operated for a long time, the lube oil in the clearance between moving parts will be lost. If operated in that condition, the engine could be damaged.

If starting the engine for the first time or after long storage, the engine should be turned over without firing to distribute lube oil according to the following procedure.

- 1) Open the kingston cock (kingston cock: optional)
- 2) Open the fuel tank valve
- 3) Shift the marine gear remote control handle to neutral
- 4) Turn the battery switch on (battery switch: local supply)
- 5) Hold the stop button on;  
Do not release the stop button while cranking. If released the engine will start.
- 6) Insert the key into the starter switch and turn the key to the ON position. The alarm buzzer should sound and the alarm lamps come on . This is normal.

(See 2.5.1(3).)

**(Note)** The C.WATER TEMP, C.WATER LEVEL and BOOST lamps will not come on.

- 7) Turn the key to the start position and hold for 5 seconds. The engine will not start. (cranking)  
This will distribute oil to the lubricated parts.
- 8) Release the stop button. Turn the key to start the engine. Release the key when the engine has started. The alarm buzzer should stop and the alarm lamps go out. Raise the engine speed gradually and check for abnormal sounds. Also check that sufficient cooling seawater is being discharged from the exhaust and that the color of the exhaust is normal. When you raise the engine speed, more cooling water should be discharged from the exhaust outlet.

### **3.2.6 Checking and Resupplying Lube Oil and Cooling Water**

When engine lube oil, marine gear lube oil or fresh water is supplied for the first time or they have to be replaced, conduct trial operation of the engine for about 5 minutes and check the quantity of lube oil and fresh water. The trial engine operation will send the lube oil and cooling water to the parts, so the lube oil and fresh water levels will fall. check and resupply lube oil and fresh water as necessary.

- 1) Resupplying engine lube oil (See 3. 2. 2.)
- 2) Resupplying lube oil to marine gear (for Yanmar model : KMH6A, KMH6A1) (See 3. 2. 3.)
- 3) Resupplying fresh water (See 3. 2. 4.)

## 3.3 How to Operate

### ⚠ WARNING



- To prevent exhaust gas poisoning, ensure good ventilation during operation. Install ventilation windows, ports or ventilators in the engine room.



- Never touch or allow your clothes to touch the moving parts of the engine during operation. If the front pulleys, V-belt, propeller shaft, etc. catch your body or clothes, serious injury may result. Check that no tools, cloth, etc. are left on or around the engine.

### ⚠ CAUTION



- The engine is very hot during operation and immediately after stopping, especially the turbocharger, fresh water tank, exhaust pipe and high pressure fuel pipe. Avoid burns! Never touch or allow your clothes to touch these parts.

### 3.3.1 Inspection before Starting

Before starting the engine, make it a daily check to conduct the following inspections:

#### (1) Visual Checks

Check for the following:

- 1) Lube Oil leakage from the engine
- 2) Fuel oil leakage from the fuel system
- 3) Water leakage from the cooling water system
- 4) Damage to parts
- 5) Loosening or loss of bolts

If any failure is found, never operate the engine before completing repairs.

#### (2) Checking and Resupplying Fuel

Check the fuel level inside the fuel tank and resupply with the recommended fuel if necessary. (See 3. 2. 1)

#### (3) Checking and Resupplying Engine Lube Oil

- 1) Check the engine lube oil level with the oil dipstick.
- 2) If lube oil level is low, resupply with the recommended lube oil to the filler port on the bonnet.  
Resupply lube oil up to the upper level mark on the lube oil dipstick. (See 3. 2. 2)

#### (4) Checking and Resupplying marine gear Lube Oil (for Yanmar model : KMH6A, KMH6A1)

- 1) Check the marine gear oil level with the oil dipstick.
- 2) If the lube oil level is low, resupply with the recommended lube oil using the filler port.  
Resupply up to the top mark on the oil dip stick. (See 3. 2. 3)

Refer to the attached operation manual for the marine gears other than model **KMH6A, KMH6A1**.

## (5) Checking and Resupplying Cooling Fresh Water

Check the fresh water level before operation while the engine is cold.

Checking the water level while the engine is hot is dangerous, and the cooling water reading will be misleading due to thermal expansion.

Only check and resupply fresh water routinely at the sub-tank. Do not remove the filler cap of the fresh water tank during operation.

- 1) Check that cooling fresh water level is in between Full and Low mark on the side of the sub-tank.
- 2) If the water level is below to the Low level mark, open the sub-tank cap and supply fresh water.
- 3) When the water in the sub-tank runs out, open the filler cap of the fresh water tank and supply water until it overflows from the filler port. (See 3. 2. 4)

### [NOTICE]

If the cooling fresh water runs out too often, or only the cooling fresh water in the fresh water tank falls without any change in the water level of the sub-tank, there may be some leakage of water or air. In such cases, consult your Yanmar dealer or distributor without delay.

### ⚠ DANGER



Do not open the filler cap during operation or immediately after stopping the engine.

Hot steam and water will spout out. To remove the cap, wait until the engine has cooled down, wrap the cap with a cloth and loosen the cap slowly. After checking, fasten the filler cap firmly.

[Fig.11]

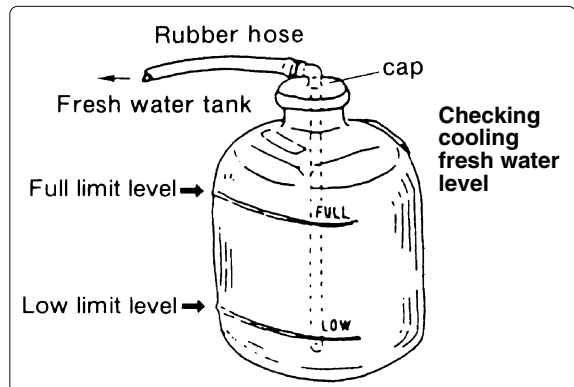
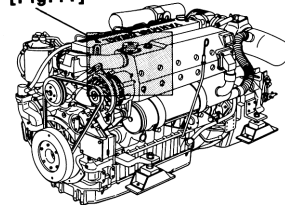

**(Note)** The water level rises in the sub-tank during engine operation. This is not an abnormality. After stopping the engine, the cooling water cools down and the extra water in the sub-tank returns to the fresh water tank.

## (6) Checking the Remote Control Handle

Be sure to check that the remote control handle lever moves smoothly before use it. If it is hard to operate, lubricate the joints of the remote control cable and also the lever bearings.

(See 4. 3. 4 (3),(4).)

### [NOTICE]

If the shift stroke of the remote control cable is inadequate at the marine gear end, it may be impossible to shift into either ahead or astern or clutch (marine gear) slippage may occur.

## (7) Checking the Alarm Devices

When operating the starter switch, check that the alarm devices work normally.

(See 2. 5. 1 (3).)

## (8) Preparing Fuel, Lube Oil and Cooling Fresh Water in Reserve

Prepare sufficient fuel for the day's operation. Always store lube oil and cooling fresh water in reserve (for at least one refill) onboard, to be ready for emergencies.

### 3.3.2 How to Start the Engine

#### (1) Start the engine according to the following procedures:

- 1) Open the Kingston cock (optional).
- 2) Open the fuel tank cock (local supply).
- 3) Pull the knob of remote control handle and tilt the lever slightly to "Ahead" .
- 4) Turn the battery switch on.
- 5) Insert the key into the starter switch and turn the key to ON: when the alarm buzzer sounds and the alarm lamps come on the alarm devices are normal.

(See 2. 5. 1 (3).)

- 6) Turn the key to START to start the engine. Release the key when the engine has started. The key returns automatically to ON. The alarm buzzer should stop and the alarm lamps go out.

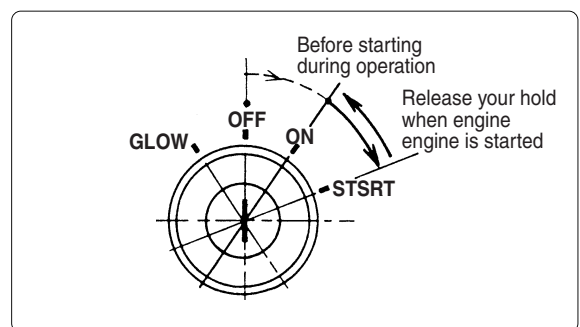
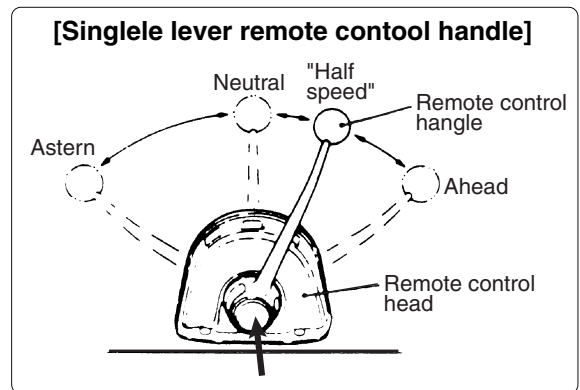

#### (2) Re-starting after Starting Failure

Before turning the starter switch key again, be sure to confirm that the engine has stopped completely. If the engine is re-started while the engine still has not stopped, the pinion gear of the starter motor will be damaged.

#### [NOTICE]

**Do not hold the starter switch on for more than 15 seconds at a time. If the engine does not start first time, wait for about 15 seconds before trying again. After the engine has started, do not turn the key OFF position. (It should return to ON.)**

**Alarm device will not work when the key is OFF.**

### (3) Start up of the engine in cold weather

When starting the engine under low temperature conditions (approx. 0°C or lower), use the air heater (optional) to enable easier starting.

- Turn the starter key from the OFF position to GLOW. Continue to hold the key in the GLOW position to heat up the air heater for about 15 seconds.
- Then, return the starter key to START to start the engine.

**Note:** When you choose the air heater (optional), we recommend you to choose the control panel (optional) having the air heater heated up indicating lamp. (New B, C, D panel). When the air heater is heated up, the lamp comes on to turn the key to START position.

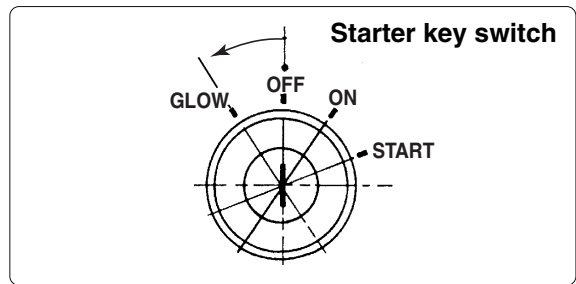

#### [NOTICE]

**Do not leave the air heater on for longer than 20 seconds at a time. Leaving the air heater on for longer periods of time will result in damage.**

### (4) After the Engine has Started

After the engine has started, check the following items at a low engine speed:

- 1) Check that the gauges and alarm devices on the control panel are normal.
- 2) Check that no water or oil leak from the engine.
- 3) Check that exhaust color, engine vibrations and sound are normal.
- 4) When there are no problems, operate the engine at low speed with the boat still stopped (warming up operation for about 5 minutes) to send lube oil to all parts of the engine.
- 5) Check that sufficient sea water is discharged from the seawater outlet pipe.  
Operation with too little seawater discharge will damage the impeller of the seawater pump. If seawater discharge is too small, stop the engine immediately, identify the cause and repair:
  - Is the Kingston cock open ?
  - Is the inlet of the Kingston cock on the hull bottom clogged ?
  - Is the seawater suction hose broken, or does the hose suck in air due to a loose joint ?

#### [NOTICE]

**The engine will be seized, if it is operated when cooling seawater discharge is still too small or load is applied without any warming up operation.**

### 3.3.3 Shifting

#### 3.3.3.1 Single-lever type remote control handle (optional)

Return the control lever to neutral before performing the following operation.

**(1) Ahead** (Forward)

Gradually tilt the control handle to "Ahead". Tilting the handle gradually to accelerating side, the clutch is thrown in and the boat sails ahead.

**(2) Astern** (Reverse)

Gradually tilt the control handle to "Astern". Tilting the handle gradually to accelerating side, the clutch is thrown in and the boat sails astern.

**(3) Neutral**

Be sure to set the clutch marine gear handle at "Neutral".

**[NOTICE]**

Do not accelerate or decelerate sharply, overload, etc. for the first 50 hours when using a new engine.

**[NOTICE]**

Engine trouble can arise, if the engine is operated for a long time under overloaded conditions with the remote control handle in the full throttle position (max. engine speed position), exceeding the maximum engine speed.

Use the engine speed of about 100rpm below than at the full throttle position.

### 3.3.4 Checking during Operation

Always be on the look out for problems during engine operation.

Pay particular attention to the following.

**(1) Is sufficient seawater being discharged from the seawater outlet pipe ?**

If the discharge is small, stop the engine immediately, identify the cause and repair.

**(2) Is the exhaust color normal ?**

The continuous black exhaust smoke shows engine overloading.

This shortens the engine's life, so should be avoided.

**(3) Are there abnormal vibrations or noise ?**

Do not operate at speeds which produce violent vibrations. Depending on the hull structure, engine and hull resonance may suddenly become great at a certain engine speed range causing heavy vibrations. Avoid operation in this speed range. If you hear any abnormal sounds, stop the engine and inspect.

**(4) Alarm buzzer sounds during operation.**

If the alarm buzzer sounds during operation, lower the engine speed immediately, check the alarm lamps, and stop the engine for repairs.

**(5) Is there water, oil, or gas leakage, or are there any loose bolts ?**

Check the engine room periodically for any problems.

**(6) Is there sufficient oil in the fuel tank ?**

Replenish fuel oil in advance to avoid running out of fuel during operation.

**(7) When operating the engine at low speed for long periods of time, race the engine once every 2 hours.**

## How to Race the Engine

Repeat a cycle of high speed and low speed operation about 5 times at no load with the clutch (marine gear) in Neutral position.

Engine racing removes carbon deposits from the cylinder and the tip of the fuel injection valve.

If racing is neglected, the exhaust color may worsen and performance may drop.

### 3.3.5 Stopping the Engine

Stop the engine according to the following procedures:

- 1) Shift the remote control leve to low engine speed and handle to Neutral position to stop the boat.
- 2) Be sure to race the engine before stopping. (See 3.3.4-(7).)
- 3) Operate the engine at low speed (approx. 1000rpm) for about 5 minutes to decrease the engine temperature.

#### [NOTICE]

**If engine is stopped quickly during high speed operation, the engine temperature will rise sharply, causing lube oil to degenerate and moving parts to stick.**

- 4) Press the stop button until the engine stops completely. If you release the button early, the engine may continue running.
- 5) Turn the starter switch to OFF. Pull out the key and store it carefully
- 6) Turn the battery switch off.
- 7) Close the fuel tank cock.
- 8) Close the kingston cock.

#### [NOTICE]

**Be sure to close the kingston cock, or water may enter and sink the boat.**

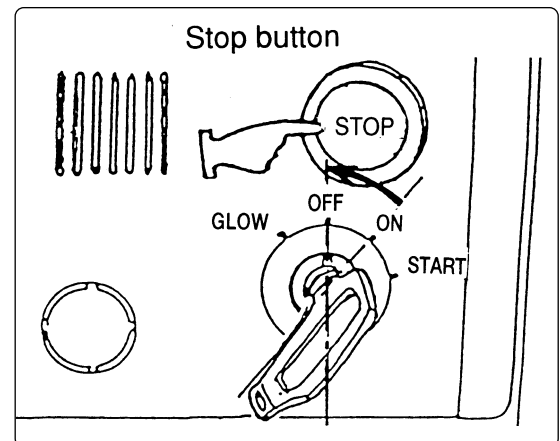



## 3.4 Long Term Storage

- (1) In cold temperatures or before long term (3 months or more) storage, be sure to drain the water from the seawater cooling system.

**[NOTICE]**

If water is left inside, it may freeze and damage parts of the cooling system (fresh water cooler, lube oil cooler, seawater pump, etc.)

- 1) Loosen the 6 bolts fixing the side cover of the seawater pump, remove the cover and drain the water from inside.
- 2) After draining, put the pump's side cover back on.
- 3) Open the seawater drain cocks (3 positions as illustrated at right for engine side) and drain the seawater.

[Fig.17] shows the position of the seawater drain cock for Yanmar model KMH6A, KMH6A1. For detailed information on models other than Yanmar models, refer to the Marine Gear Operation Manual.

- 4) Close the drain cocks after draining the seawater

- (2) Be sure to drain from the fresh water cooling system if LLC is not used.

- 1) Open the fresh water drain cocks (2 positions) and drain the fresh water.
- 2) Close the drain cocks after draining the fresh water.

**[NOTICE]**

If the water is not drained, it may freeze and damage parts of the cooling water system (fresh water tank, fresh water cooler, cylinder block, cylinder head, etc.)

- (3) Carry out the next periodic inspection before placing the engine in storage. Remove dust and wipe off oily contamination from the outside of the engine. Clean the engine.

- (4) To prevent condensation inside the fuel tank, either extract all fuel or fill the tank.

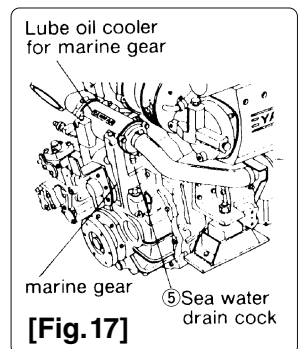
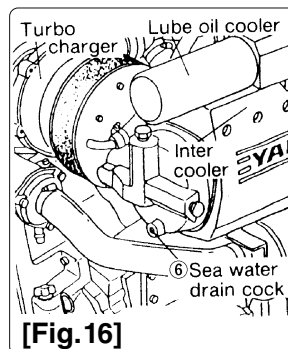
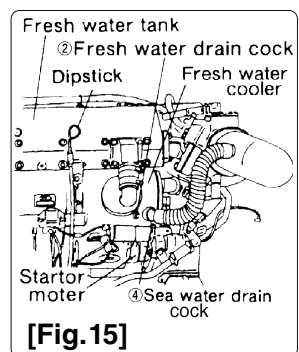
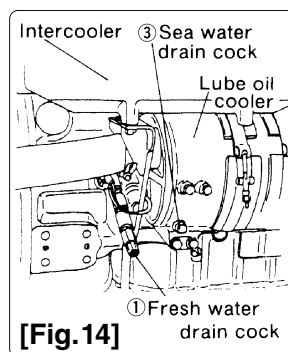
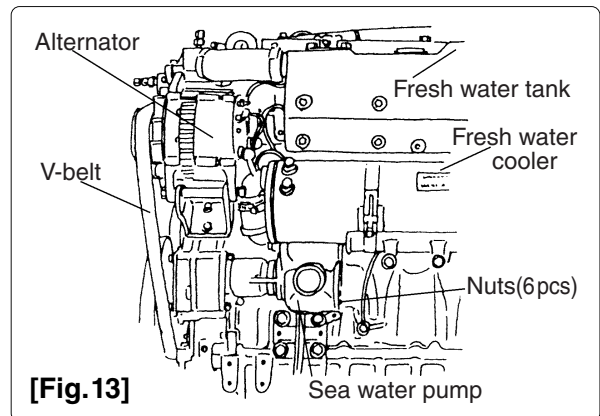
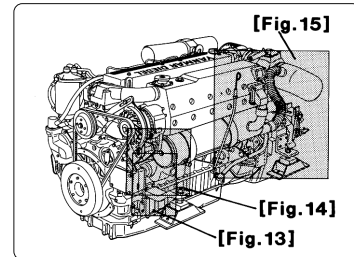
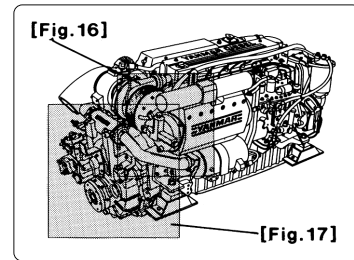

- (5) Oil and grease the exposed area and joints of the remote control cable and the bearings of the remote control handle.
- (6) Cover the turbocharger, exhaust pipe, etc. with vinyl sheets and seal them to prevent moisture from entering.
- (7) Drain bilge in the hull bottom completely.  
(If water leakage is found in the hull and water can enter, the boat must be hauled for repair.)
- (8) Water-proof the engine room to prevent rain and seawater from entering.
- (9) During long-term storage, charge the battery once a month to compensate for the battery's self-discharge.
- (10) When using the engine after long storage, follow the procedures for starting a new engine.

# 4. Maintenance & Inspection

## 4.1 General Inspection Rules

### Conduct Periodic Inspection for Your Safety:

The functions of engine components will degenerate and engine performance will fall if periodic inspections are not performed. If the countermeasures of the problems are not taken, you may encounter unexpected troubles while cruising at sea. If the periodic inspections are not performed, consumption of fuel or lube oil may become excessive and exhaust gas and engine noise may increase.

These all shorten the life of the engine. Daily and periodic inspection and servicing increase your safety operation.

### Inspect before Starting:

Make it a daily rule to inspect before starting.

### Periodic Inspections at Fixed Intervals:

Periodic inspections must be made after 50, 250 (or 1 yr.), 500 (or 2 yrs.), 1000 (or 4 yrs.) and 2000 hours of use. Monitor the hourmeter and conduct periodic inspections according to the procedures described in this operation Manual.

### Use Genuine Parts:

Be sure to use genuine parts for consumable and replacement parts.

Use of other parts will reduce engine performance and shorten the life of the engine.

### Servicing Tools:

Prepare servicing tools onboard to be ready for inspecting and servicing the engine and other equipment.

### Tightening Torque of Nuts & Bolts:

Over-tightening of bolts and nuts causes them to come off or their threads to be damaged. Insufficient tightening causes oil leakage from the installation face or troubles due to the loosening of bolts. Nuts and Bolts must be tightened to the appropriate tightening torque. Important parts must be tightened with a torque wrench to the correct tightening torque and in the right order. Consult with your dealer or distributor if the servicing requires the removal of such parts.

### The tightening torque for standard nuts & bolts is listed below:

#### [NOTICE]

- Apply the following tightening torque to bolts having "7" on the head. (JIS strength classification : 7T)
- Tighten bolts with no "7" mark to 60% tightening torque.
- If the parts to be tightened are made from aluminum alloy, tighten the bolts to 80% tightening torque.



| Bolt dia. × pitch | mm             | M6 × 1.0                  | M8 × 1.25                 | M10 × 1.5                 | M12 × 1.75                | M14 × 1.5                 | M16 × 1.5                 |
|-------------------|----------------|---------------------------|---------------------------|---------------------------|---------------------------|---------------------------|---------------------------|
| Tightening torque | N·m<br>(Kgf·m) | 10.8 ± 1.0<br>(1.1 ± 0.1) | 25.5 ± 2.9<br>(2.6 ± 0.3) | 49.0 ± 4.9<br>(5.0 ± 0.5) | 88.3 ± 9.8<br>(9.0 ± 1.0) | 137 ± 9.8<br>(14.0 ± 1.0) | 226 ± 9.8<br>(23.0 ± 1.0) |

## 4.2 Periodic Inspection

Daily and periodic inspection are important to keep the engine in its best condition. The following is a summary of inspection and servicing items by inspection interval. Periodic inspection intervals should vary depending on the uses, loads, fuels and lube oils used and handling conditions, and are hard to establish definitively. The following should be treated only as a general standard.

### [NOTICE]

**Schedule your own periodic inspection plan according to the operational conditions of your engine and inspect every item. Neglect of periodic inspection may lead to engine troubles and shorten the life of the engine. Inspection and servicing at 2000 hours of operation and thereafter require special knowledge and techniques. Consult your dealer or distributor or the Yanmar subsidiary in your region.**

### Preiodical Inspection and Maintenance.

● : Consult nearest dealer  
○ : Check    ⊙ : Replace

| Item                             | Description   | Schedule |                       |                                   |                                    |                                     |                         | Page     |
|----------------------------------|---|----------|-----------------------|-----------------------------------|------------------------------------|-------------------------------------|-------------------------|----------|
|                                  |   | Daily    | Every 50 service hrs. | Every 250 service hrs. (or 1 yr.) | Every 500 service hrs. (or 2 yrs.) | Every 1000 service hrs. (or 4 yrs.) | Every 2000 service hrs. |          |
| Fuel                             | Check of fuel level   | ○        |                       |                                   |                                    |                                     |                         | 20       |
|                                  | Draining of tank  |          | ○                     |                                   |                                    |                                     |                         | 37       |
|                                  | Drain of filter and water separator                                     |          | ○                     |                                   |                                    |                                     |                         | 37<br>39 |
|                                  | Replacement of filter element   |          |                       | ⊙                                 |                                    |                                     |                         | 41       |
| Engine lube oil                  | Check oil level in oil pan, add if necessary                            | ○        |                       |                                   |                                    |                                     |                         | 21       |
|                                  | Replacement of filter element   |          | ⊙<br>(1st time)       | ⊙                                 |                                    |                                     |                         | 36       |
|                                  | Cleaning of lube oil cooler   |          |                       |                                   |                                    |                                     | ●                       | 44       |
|                                  | Change of lube oil  |          | ⊙<br>(1st time)       | ⊙                                 |                                    |                                     |                         | 36       |
| Cooling water (seawater side)    | Check of cooling water discharge  | ○        |                       |                                   |                                    |                                     |                         | 29       |
|                                  | Check and replacement of impeller                                       |          |                       |                                   |                                    | ○                                   | ●                       | 43       |
|                                  | Cleaning of seawater system (including fresh water and lube oil cooler) |          |                       |                                   |                                    | ○                                   | ●                       | 44       |
|                                  | Replacement of anti-corrosive zinc                                      |          |                       | ⊙                                 |                                    |                                     |                         | 42       |
| Cooling water (fresh water side) | Check and supply of fresh water level                                   | ○        |                       |                                   |                                    |                                     |                         | 26       |
|                                  | Replacement of fresh water  |          |                       | ⊙                                 |                                    |                                     |                         | 43       |
|                                  | Cleaning of fresh water system (including heat exchanger tank)          |          |                       |                                   |                                    |                                     | ●                       | 44       |

| Item   | Description   | Schedule |                       |                                   |                                    |                                     |                         |          |
|--|---|----------|-----------------------|-----------------------------------|------------------------------------|-------------------------------------|-------------------------|----------|
|  |   | Daily    | Every 50 service hrs. | Every 250 service hrs. (or 1 yr.) | Every 500 service hrs. (or 2 yrs.) | Every 1000 service hrs. (or 4 yrs.) | Every 2000 service hrs. | Page     |
| Fuel injection pump and fuel injection valve | Adjustment of injection timing  |          |                       |                                   |                                    |                                     | ●                       | 45       |
|  | Overhaul and check of fuel feed pump  |          |                       |                                   |                                    |                                     | ●                       | 45       |
|  | Adjustment of injection pressure and atomizing condition                    |          |                       | ●<br>(1st time)                   |                                    | ●                                   |                         | 44       |
| Cylinder head                                | Adjustment of clearance intake and exhaust valve                            |          |                       | ●<br>(1st time)                   |                                    | ●                                   |                         | 44       |
|  | Lapping the intake/exhaust valve  |          |                       |                                   |                                    |                                     | ●                       | 45       |
| Check and adjustment of remote control cable |   | ○        |                       | ○                                 |                                    |                                     |                         | 39<br>40 |
| Electrical parts                             | Check of alarm devices  | ○        |                       |                                   |                                    |                                     |                         | 14       |
|  | Check of battery electrolyte volume   |          | ○                     |                                   |                                    |                                     |                         | 38       |
|  | Adjustment of alternator(generator) drive belt tension                      |          |                       |                                   | ○                                  |                                     |                         | 43       |
| Turbo charger                                | Cleaning of blower  |          |                       | ○                                 |                                    |                                     |                         | 40       |
| Marine gear(Yanmar marine gear)              | Check and cleaning of lube oil cooler                                       |          |                       |                                   |                                    |                                     | ●                       | 44       |
|  | Check and cleaning of lube oil inlet filter net                             |          | ○<br>(1st time)       | ○<br>(2nd time)                   |                                    | ○                                   |                         | 37       |
|  | Check of bearings, friction plate, and seal                                 |          |                       |                                   |                                    |                                     | ●                       | 44       |
|  | Check of lube oil level   | ○        |                       |                                   |                                    |                                     |                         | 27       |
|  | Replacement of lube oil   |          | ◎<br>(1st time)       | ◎<br>(2nd time)                   |                                    | ◎                                   |                         | 27       |
| General                                      | Check for leakage of C.W., L.O., F.O. and exh. gas (including mixing elbow) | ○        |                       |                                   |                                    |                                     |                         | 28       |

## 4.3 Periodic Inspection Items

### 4.3.1 Inspection after Initial 50 Hrs. Operation

#### (1) Replacing the Engine Lube Oil and Lube Oil Filter (1st time)

During initial operation of the engine, the oil is quickly contaminated due to the initial wear of internal parts. The lube oil must therefore be replaced early.

Replace the lube oil filter, too, at this time.

Engine lube oil is convenient to drain before the engine has cooled down.

- ① Remove the lube oil dipstick and connect the hose of the drain oil pump (optional part) to the guide of the oil dipstick.
- ② Prepare a container to receive drain oil and pump out oil using the drain oil pump.
- ③ Remove the lube oil filter with the filter wrench.  
(Turn counterclockwise.)
- ④ Clean the filter installation face.
- ⑤ Screw the lube oil filter fully into the installation face by hand and further fasten the filter by about 3/4 turns with the filter wrench.  
(Turn clockwise.)
- ⑥ Supply new lube oil to the specified level.  
(See 3. 2. 2.)  
Test operation the engine for 5 minutes.  
Check that no oil leaks out during operation.
- ⑦ Wait about 10 minutes after stopping the engine. Check the oil level with the oil dipstick and refill to the specified level.

| Lube oil filter Yanmar P/N |              |
|----------------------------|--------------|
| Full flow                  | 119593-35100 |
| By-pass                    | 119593-35400 |

#### ⚠ CAUTION



Beware of oil splashes if extracting the lube oil while it is hot.

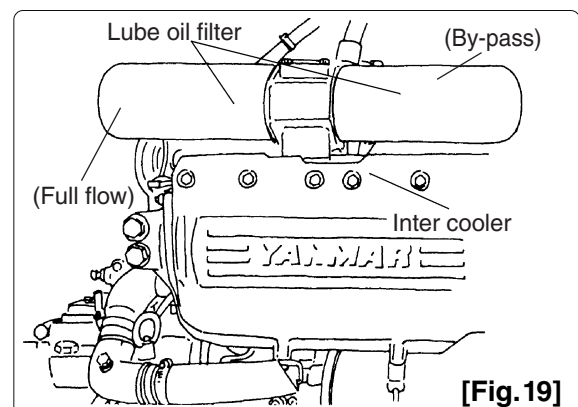
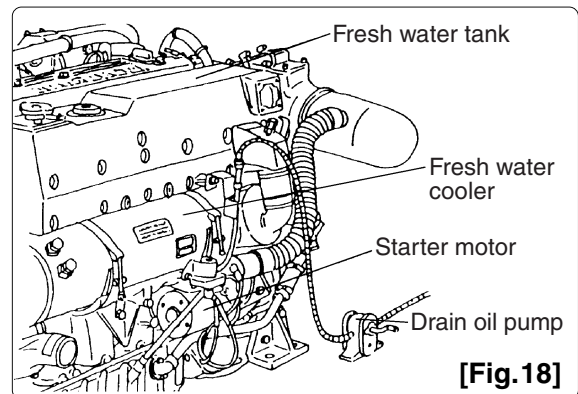
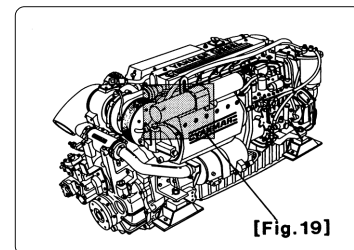
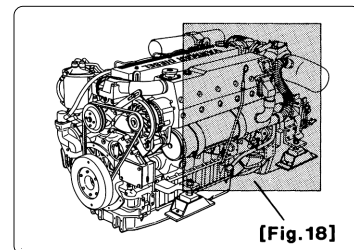

## (2) Replacing Marine gear Lube Oil and Cleaning the Filter (1st time)

During initial operation of the engine, the lube oil is contaminated quickly due to initial wear. The lube oil must be replaced early. Clean the clutch lube oil filter, too, at this time.

- ① Remove the filler port cover, insert the drain oil pump hose to the bottom of the marine gear and pump out the lube oil from inside the marine gear.
- ② Remove the filter in the side cover, extract the filter and clean the filter with kerosene.
- ③ When installing the filter, attach the side cover by pressing it by coil spring.  
Do not forget to place the O-ring inside the side cover.
- ④ Supply new lube oil to the specified level.

(See 3. 2. 3.)

- ⑤ Trialily operate the engine and check that no oil leaks.

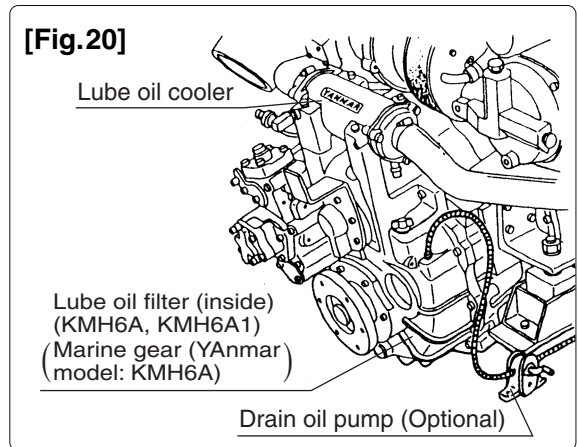
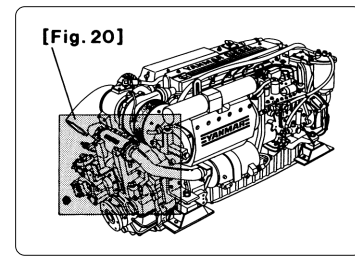

## 4.3.2 Inspection Every 50 Hours

### (1) Draining of the Fuel Tank (Hull) (local supply)

Open the drain cock of the fuel tank to extract drain (water, dust, etc.) from the tank's bottom. Receive the drain in a container. Drain until fuel with no water and dust flows out. Then close the drain cock.

### (2) Draining of the Oil / Water Separator (optional)

- ① Close the fuel cock.
- ② Remove the drain plug at the bottom of the oil/water separator and drain water and dust from inside.
- ③ After draining of the oil / water separator, be sure to vent air from the fuel system.  
(See 3. 3. 2 (3))

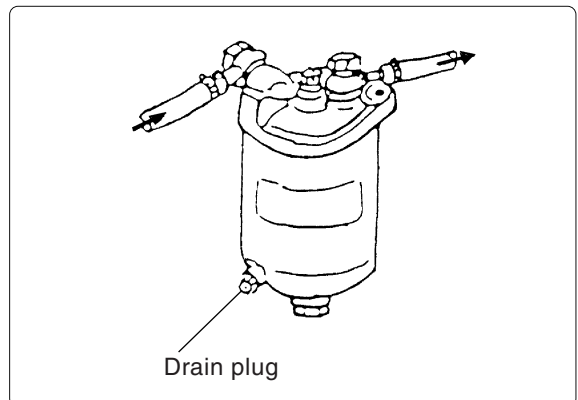

### (3) Inspection of Battery

#### ⚠ WARNING



#### Fire due to Electric Short-Circuits

Always turn off the battery switch or detach the earth cable (-) before inspecting the electrical system. Failure to do so could cause short-circuiting and fires.



#### Proper Ventilation of the Battery Area

Be sure the area around the battery is well-ventilated and there is nothing which could start a fire. During operation and charging, hydrogen gas is emitted from the battery and can be easily ignited.



#### Battery Fluid

Battery fluid is diluted sulfuric acid. It can blind you if it gets in your eyes, or burn your skin. Keep the fluid away from your body. Wash it off immediately with a large quantity of fresh water if you get any on you.

- Check the level of fluid in the battery.  
When the amount of fluid nears the lower limit, fill with battery fluid (available in the market) to the upper limit. If operation continues with insufficient battery fluid, the battery life is shortened, and the battery may overheat and explode.
- Battery fluid tends to evaporate more quickly in the summer, and the fluid level should be checked earlier than the specified times.
- If the engine turns over at a slower than usual rate and refuses to start, recharge the battery.
- If the engine still will not start after charging, replace the battery.

#### Local supply

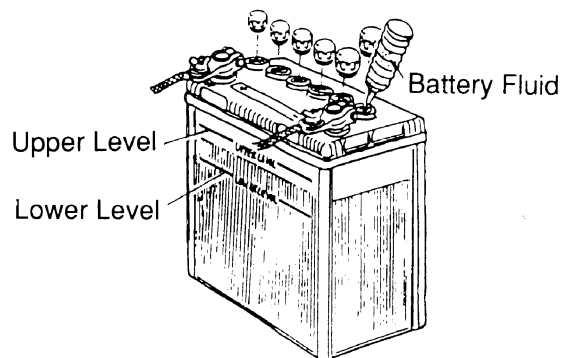

Follow the instructions and precautions in the manual from the battery maker.

#### [NOTICE]

The capacity of the specified alternator and battery is sufficient for regular operation, however, the capacity may be insufficient, if they are used for other purposes such as lights inside the boat, etc. Consult your Yanmar dealer or distributor.



#### (4) Draining the fuel oil filter

- 1) Remove the drain plug at the bottom of fuel oil filter and discharge water and dust collected in the fuel oil filter.
- 2) After draining bleed air from the fuel system.

(For further details, see Sec. 3. 2. 1 (2))

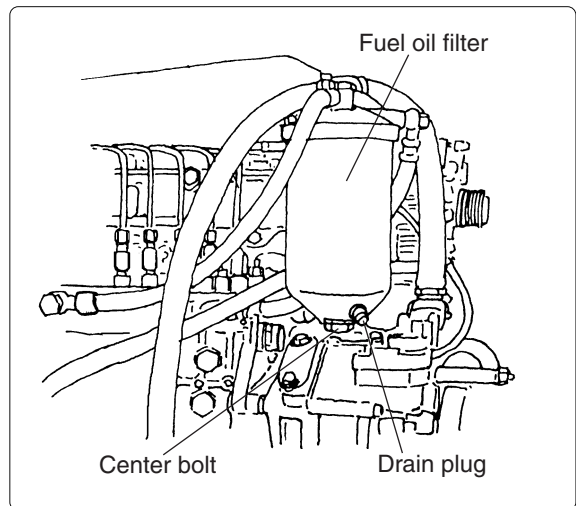

### 4.3.3 Inspection after First 250 Hrs.

#### (1) Inspection and Adjustment of Intake/Exhaust Valve Head Clearance (1st Time)

Inspection and adjustment must be made to correct opening/closing timing lags of the intake/exhaust valves which might arise due to initial parts wear. This inspection requires specialized knowledge and techniques. Consult your Yanmar dealer or distributor.

#### (2) Inspection and Adjustment of Fuel Injection Valve (1st Time)

Inspection and adjustment are necessary to obtain optimal fuel injection to ensure the good engine performance. This inspection requires specialized knowledge and techniques. Consult your Yanmar dealer, or distributor.

### 4.3.4 Inspection Every 250 Hrs.(or 1 yr.)

#### (1) Replacement of Marine gear Lube Oil and cleaning the Filter (2nd time)

Replace marine gear lube oil and clean filter for the second time.

#### (2) Replacing the Engine Lube oil and Filter

Replace the engine lube oil every 250 hours. Replace the lube oil filter, too. (See 4.3.1(1).)

#### (3) Adjusting the (Governor Lever) Engine Speed Control Cable

Check the (governor lever) speed control lever at the engine side makes uniform contact with the high speed and low speed side stopper when the remote control handle is in the high speed (high idle) or low speed (idle) position. If either the high speed or the low speed side does not make contact with stopper. adjust as follows (next page):

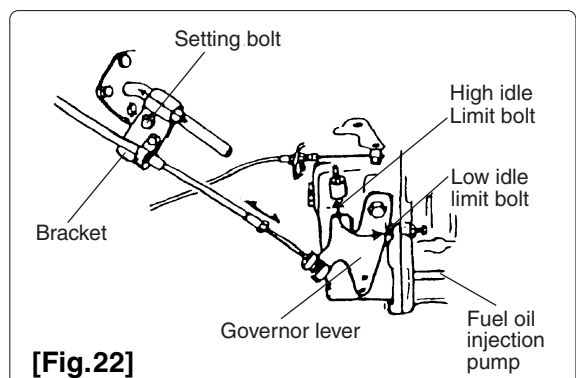
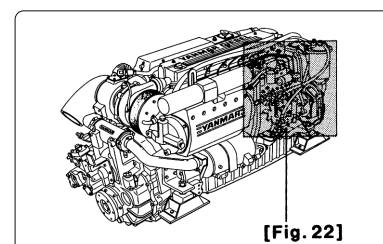

- ① Remove the threaded area and the connecting pivot of the remote control cable from the governor lever. Adjust the cable stroke by adjusting the fastening distance of the threaded area.
- ② Loosen the setting bolt of the remote control cable clamp bracket and adjust the fixing position of the remote control cable.  
(However, the adjustment of the remote control cable stroke must be made as in ① above.)

#### (4) Adjusting the Marine Gear Remote Control Cable

- ① Check to see that the clutch lever on the marine gear side is in the neutral position when the remote control handle is in **NEUTRAL**.
- ② If the position of the clutch lever is incorrect, loosen the setting screw of the cable bracket and adjust the position of the cable.
- ③ Check the clutch lever in
  - ▲ **FWD** (Forward) (Ahead )
  - ▼ **REV** (Reverse) (Astern)
 making sure it is correctly aligned.
- ④ Make any necessary adjustments using **NEUTRAL** as the central point.
- ⑤ Make sure the control cable is securely fastened to the clutch lever.  
For other models, refer to the marine gear operation manual.

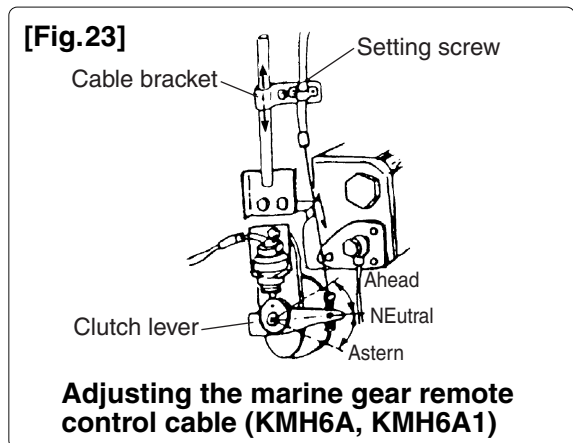
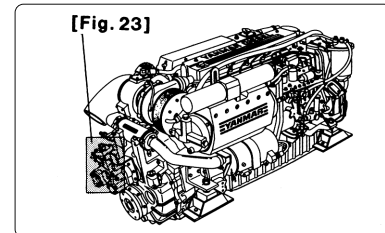

#### (5) Cleaning the Turbocharger Blower

Contamination of the turbocharger blower causes blower speed to drop and engine output to down.

- ① Prepare blower cleaning agent, fresh water and a small pitcher.
- ② Remove the pre-cleaner (filter) of the turbocharger air inlet.
- ③ Pour about 50cc of blower cleaning agent little by little at about 10 second intervals through the air inlet under no load operation (2500~3000 rpm)
- ④ Wait about 3 minutes, and pour 50cc fresh water into the air inlet in the same manner at about 10 second intervals.

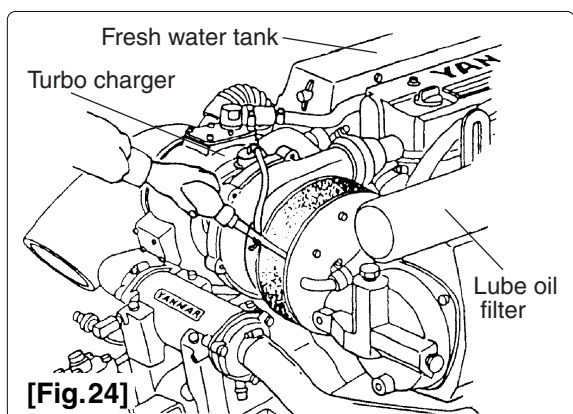
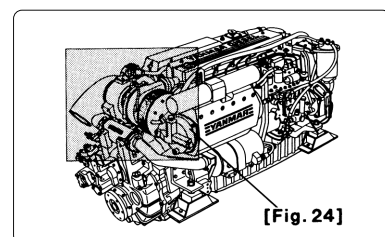

⑤ Run the engine at load for about 10 minutes to dry the turbocharger and check that engine output has recovered.

If the output has not recovered, repeat the above cleaning cycle 3 or 4 times.

If the output still has not recovered, consult your Yanmar dealer or distributor.

⑥ Clean the pre-cleaner with detergent, dry it and install it to the blower air inlet.

Replace the pre-cleaner(filter), if broken.

|                          |              |
|--------------------------|--------------|
| Blower wash agent (4 ℓ ) |              |
| Yanmar P/N               | 974500-00400 |

**[NOTICE]**

**Do not pour a large quantity of blower cleaning agent or fresh water in at once. The blower may be broken or water-hammer may occur.**

**(6) Replacing the Fuel Filter Element**

Replace the fuel filter element periodically before there is clogging and the fuel flow is reduced.

① Close the fuel cock of the fuel tank.

② Remove the drain plug and discharge the fuel oil in the fuel filter. (put a pan under the drain to catch the fuel)

③ Loosen center bolt of the filter, remove the lower case, and replace the element.

④ Bleed air the fuel system. (See 3.2.1(2))

|                     |              |
|---------------------|--------------|
| Fuel filter element |              |
| Yanmar P/N          | 41650-550810 |

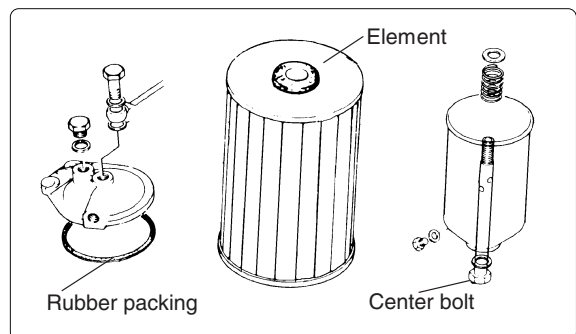
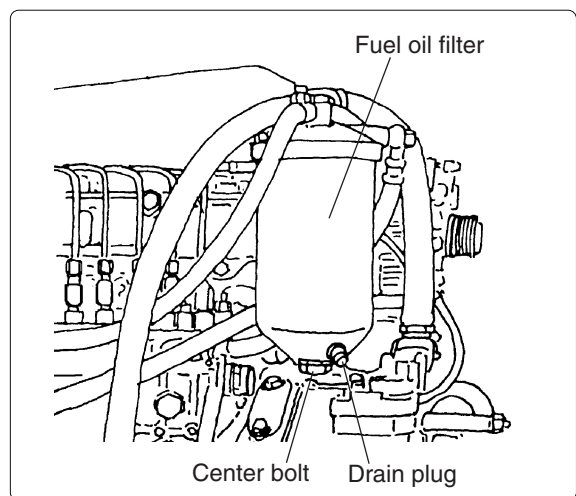

**(7) Inspecting and Replacing Anticorrosive Zinc**

The timing for replacing anticorrosive zinc varies depending on the characteristics of the seawater and operational conditions.

Inspect the zinc periodically and remove the corroded area on the surface.

Replace the anticorrosive zinc when it has decreased to less than 1/2 of the original volume. If replacement of zinc is neglected and operation is continued with a small volume of anticorrosive zinc, corrosion of the seawater cooling system will occur and water leakage or parts breakage will result.

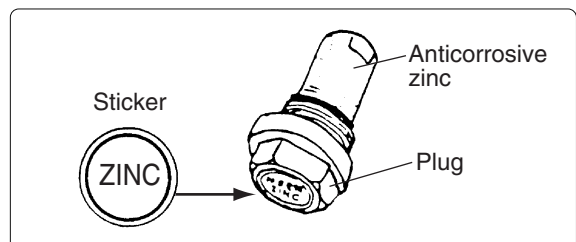

The label shown in the figure is stuck on the plugs which have the anticorrosive zinc.

Be sure to close the kingston cock before removing the plug to replace the anticorrosive zinc.

**<Note>**

[Fig 29] shows the position of the Yanmar marine gear (Model KMH6A).

For detailed information on marine gears other than Yanmar ones, refer to the Marine Gear Operation Manual.

| Attached zinc location      | Yanmar P/N                | Qty |
|-----------------------------|---------------------------|-----|
| Inter-cooler                | 119574-18790              | 1   |
| Marine gear lube oil cooler | 27210-200370 (KMH6A only) | 1   |
| Engine lube oil cooler      | 119574-44150              | 2   |
| Fresh water cooler          | 119574-44150              | 2   |

Marine gear KMH6A : has no zinc.

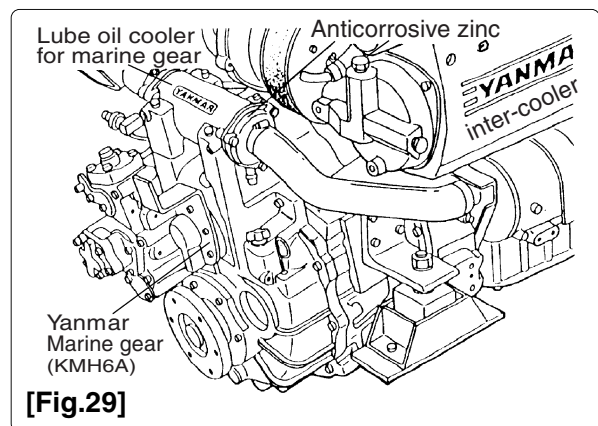
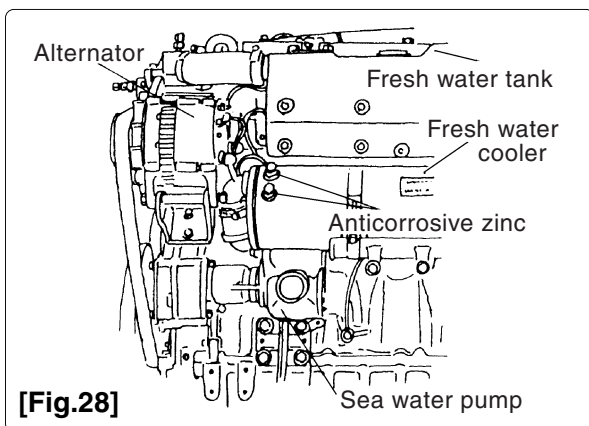
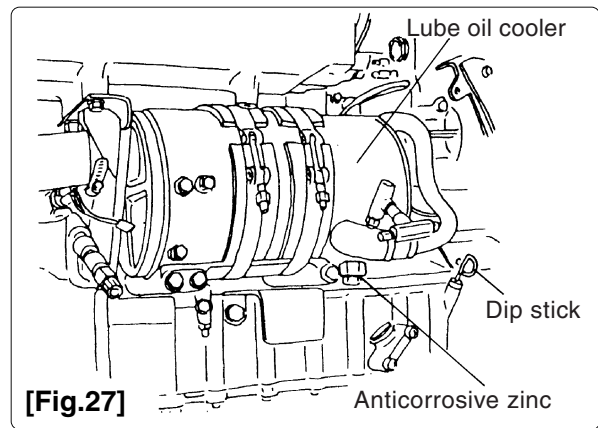
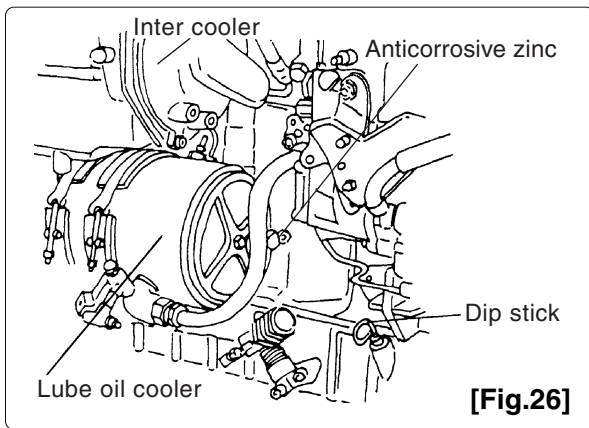
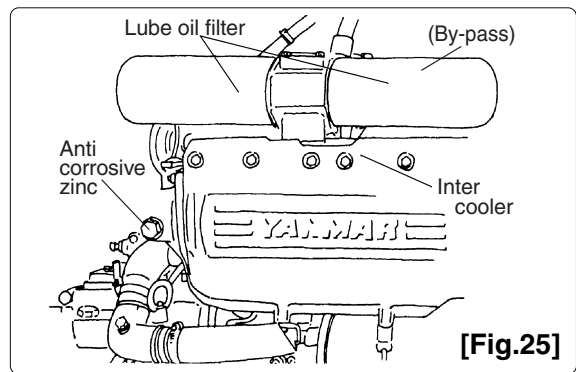
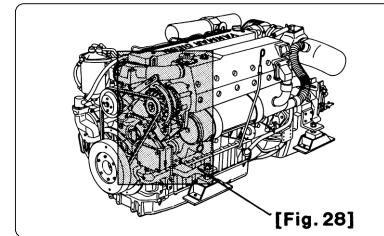
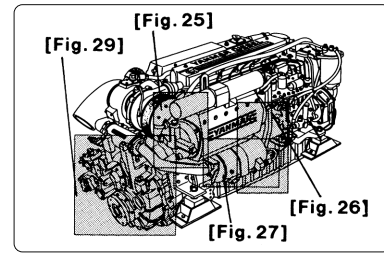

## (8) Replacing Cooling Fresh Water

Cooling performance drops when cooling water is contaminated with rust and scale. Even if LLC is added, the cooling water must be periodically replaced because the properties of the agent will degenerate.

To extract the cooling water, open the cooling water cocks (two positions) as shown in 3.4(2).

To resupply cooling water, refer to 3. 2. 4.

### 4.3.5 Inspection Every 500 Hrs.(or 2 yrs.)

#### (1) Inspection of Alternator V-Belt Tension

When the V-belt tension falls, the alternator will fail to generate power due to V-belt slippage, the cooling water pump will fail to supply cooling water and overheating of the engine will occur.

When the V-belt tension is too tight, the V-belt is liable to earlier damage and the bearings of the alternator and cooling water pump may be damaged.

- ① Check the tension of the V-belt by pressing the middle of the belt with your finger. With proper flexion, the V-belt should sink 8~10mm.
- ② Loosen the set bolt and move the alternator to adjust V-belt tension.
- ③ Be careful not to deposit oil on the V-belt. If stained with oil, it is liable to slip and to stretch. If damaged replace a V-belt.

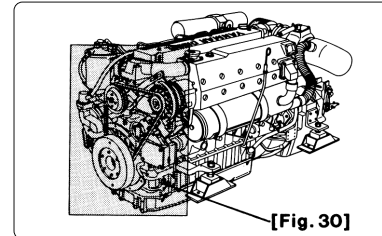

[Fig. 30]

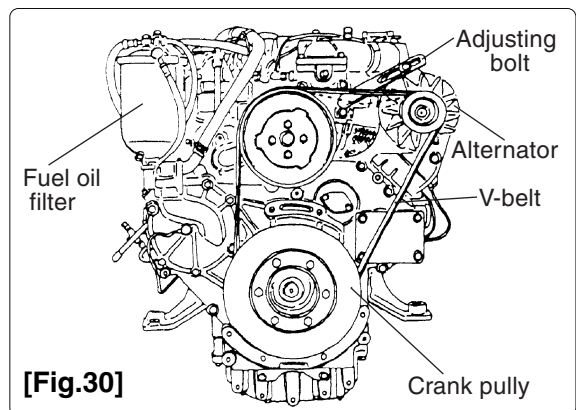

[Fig.30]

| V-belt     |              |
|------------|--------------|
| Yanmar P/N | 119593-42280 |

### 4.3.6 Inspection Every 1000 Hrs.(or 4 yrs.)

#### (1) Inspecting Inner Parts of the Seawater Pump

The discharge performance of the seawater pump falls depending on the use.

The seawater pump must be inspected periodically. If the discharge volume of cooling seawater has decreased: (When disassembly servicing of the seawater pump is necessary, consult yanmar dealer or distributor.)

- ① Loosen the side cover set bolts and remove the side cover. (6 mounting bolts)
- ② Illuminate the inside of the the seawater pump with a flashlight and inspect.
- ③ When the following damage is found, disassembly and maintenance are necessary:

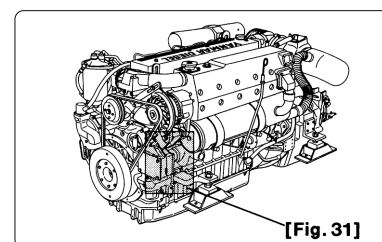

[Fig. 31]

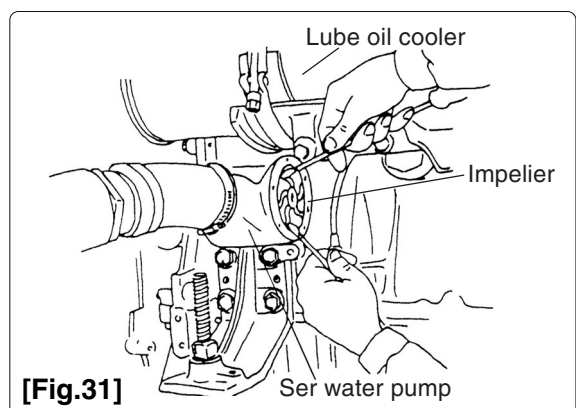

[Fig.31]

1) Cracks and loss of impeller ; flaws or excessive wear of impeller tips and side faces.

**(Note)** The impeller must be replaced periodically (every 2000 hours).

2) Damage to wear plate

④ If there is no problem with the inner parts, fit the O-ring to the groove of the joint face and re-install the side cover.

If water leaks continuously from the water drain pipe beneath the seawater pump during operation, disassembly and maintenance (replacement of the oil seal) is necessary.

**[NOTICE]**

**The seawater pump revolves clockwise, but the impeller blades must be reinstalled in the counterclockwise direction. During reassembly, be sure to install the impeller blades correctly as shown in the illustration at right. When turning the engine manually, never turn it in the reverse direction. The impeller will be twisted and damaged.**

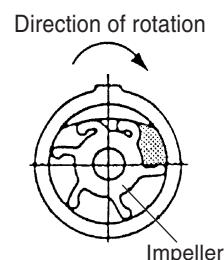

**(2) Inspection and Adjustment of Intake/Exhaust Valve Clearance**

Inspection and adjustment must be made to correct the opening/closing timing lags of the intake/exhaust valves. This inspection requires specialized knowledge and techniques. Consult your Yanmar dealer or distributor

**(3) Inspecting and Adjusting the Fuel Injection Valve**

Adjustment is necessary to obtain the optimal fuel injection to ensure the good engine performance. This inspection requires specialized knowledge and techniques. Consult your Yanmar dealer or distributor.

**(4) Replace the marine gear oil and clean filter.**

**4.3.7 Inspection Every 2000 Hrs.**

**(1) Cleaning the Cooling Water System and Inspecting & Adjusting Parts**

Rust and scale are deposited inside the seawater and fresh water cooling systems during long use.

This lowers cooling performance, so it is necessary to clean and maintain the following parts in addition to replacing the cooling water.

The internal contamination of the engine lube oil coolers reduces cooling efficiency and accelerates lube oil coolers degeneration.

Servicing jobs above require specialized knowledge.

Consult your Yanmar dealer or distributor.

**Relevant Cooling Water System Parts:**

- Seawater pump, engine lube oil cooler,**
- intercooler, fresh water pump, fresh water cooler, thermostat, etc.**

## **(2) Lapping of Intake/Exhaust Valves**

Adjustment necessary to maintain proper contact of valves and seats.

This maintenance requires specialized knowledge.

Consult your Yanmar dealer or distributor.

## **(3) Inspection and Adjustment of Fuel Injection Timing**

Fuel injection timing must be adjusted to ensure optimal engine performance.

This maintenance requires specialized knowledge.

Consult your Yanmar dealer or distributor.

# 5. Troubleshooting

| Trouble   | Probable Cause   | Measure  | Reference                              |
|---|--|--|--|
| <p>● Alarm buzzer sounds and alarm lamps go on during operation</p> <p>○ Eng. L.O. Press. Warning Lamp goes on.</p> <p>○ Marine gear lube oil pressure warning light goes on. (if having)</p> <p>○ C.W. Temp.(Fresh Water) Warning Lamp goes on.</p> <p>○ Fuel Oil Warning Lamp goes on. (if having)</p>  | <p><b>[NOTICE]</b><br/> <b>Shift to low speed operation immediately, check which lamp has come on and stop the engine for inspection.</b><br/> <b>If no abnormality is identified and there is no problem with operation, return to port at your lowest speed and request repairs.</b></p> |  |  |
|   | <p>Engine L.O. insufficient;<br/>L.O. filter clogged.</p>  | <p>L.O. level check, resupply, replace<br/>Replace L.O. filter<br/>Replace Eng. L.O.</p>             | <p>3.2.2<br/>4.3.1(1)<br/>4.3.1(1)</p> |
|   | <p>Insufficient marine gear lube oil</p>   | <p>Check the oil level and supply.</p>   | <p>3.2.3</p>                           |
|   | <p>Fresh water cooler water level low.<br/>Cooling seawater discharge insufficient<br/>Contamination inside the cooling system.</p>  | <p>Check C.W. level resupply<br/>System clogged; air has entered the system<br/>Ask for repairs.</p> | <p>3.2.4(1)</p>                        |
| <p>● Warning Devices are Faulty.<br/>When Switch is Turned ON:</p> <p>○ Alarm buzzer does not sound</p> <p>○ Warning lamps do not go on<br/>-Eng. L.O. Press, Exhaust.</p> <p>○ Charge lamp does not go on.</p> <p>When the Key Returned to ON from START after Engine Starting:</p> <p>○ Buzzer keeps on sounding</p> <p>○ One of the warning lamps does not go out.</p> | <p><b>[NOTICE]</b><br/> <b>Do not run the engine with alarm devices still unrepaired.</b><br/> <b>Trouble will progress and a serious problems may result.</b></p>   |  |  |
|   | <p>Circuit broken or buzzer defective.</p>   | <p>Ask for repairs.</p>  | <p>2.5</p>                             |
|   | <p><b>(Note) Other warning lamps do not go on when the switch is turned on. They only go on when there is an abnormality.</b></p> <p>Circuit broken or lamp burnt out.</p>   | <p>Ask for repairs.</p>  |  |
|   | <p>Short-circuit (if lamp goes out)<br/>Sensor switches faulty</p>   | <p>Ask for repairs.</p>  |  |
|   |  | <p>Ask for repairs.</p>  |  |



| Trouble   | Probable Cause  | Measure   | Reference                |
|---|---|---|--------------------------|
| <input type="radio"/> Charge lamp does not go out during operation                              | V-belt broken or loose<br><br>Battery defective.<br><br>Alternator power generation failure   | Replace V-belt; adjust tension<br>Check fluid level, specific gravity; replace.<br>Ask for repairs.   | 4.3.5(1)<br><br>4.3.2(3) |
| <p><b>● Starting Failures</b></p> <input type="radio"/> Starter works but engine does not start | No fuel<br>Improper fuel<br>Fuel injection faulty.<br>Compression leaks from intake/exhaust valve.  | Resupply fuel; bleed air.<br>Use recommended fuel.<br>Ask for repairs.<br><br>Ask for repairs.  | 3.2.1(1)<br>3.1.1        |
| <input type="radio"/> Starter does not work or works only slowly. (eng.can be turned manually)  | Neutral safety switch engaged<br>Battery charging insufficient.<br>Cable terminal contact failure<br>Switch of safety device faulty.<br>Starter switch faulty.<br>Battery power lacking due to other use. | Shift clutch to Neutral.<br>Check fluid level; re-charge; replace.<br>Remove rust from terminal; retighten.<br><br>Ask for repairs.<br>Ask for repairs.<br><br>Consult your dealer. | 3.3.2(1)<br>4.3.2(3)     |
| <input type="radio"/> Engine can't be turned manually   | Internal parts seized; broken.  | Ask for repairs.  |                          |
| <p><b>● Poor Exhaust Color</b></p> <input type="radio"/> Black smoke                            | Load increased<br><br>Turbocharger blower contaminated.<br>Fuel improper.<br>Faulty spraying by F.O. injection valve<br>Int./exh. valve head clearance excessive  | Inspect propeller system<br><br>Clean blower.<br>Use recommended fuel<br><br>Ask for repairs.   | 3.1.1                    |
| <input type="radio"/> White smoke   | Improper fuel<br>Faulty spraying by F.O. injection valve<br>F.O. injection timing lags<br>Lube oil burns; excessive consumption   | Use recommended fuel<br><br>Ask for repairs.<br>Ask for repairs.<br><br>Ask for repairs.  | 3.1.1                    |

# 6. SYSTEM DIAGRAMS

## 6.1 Piping diagram

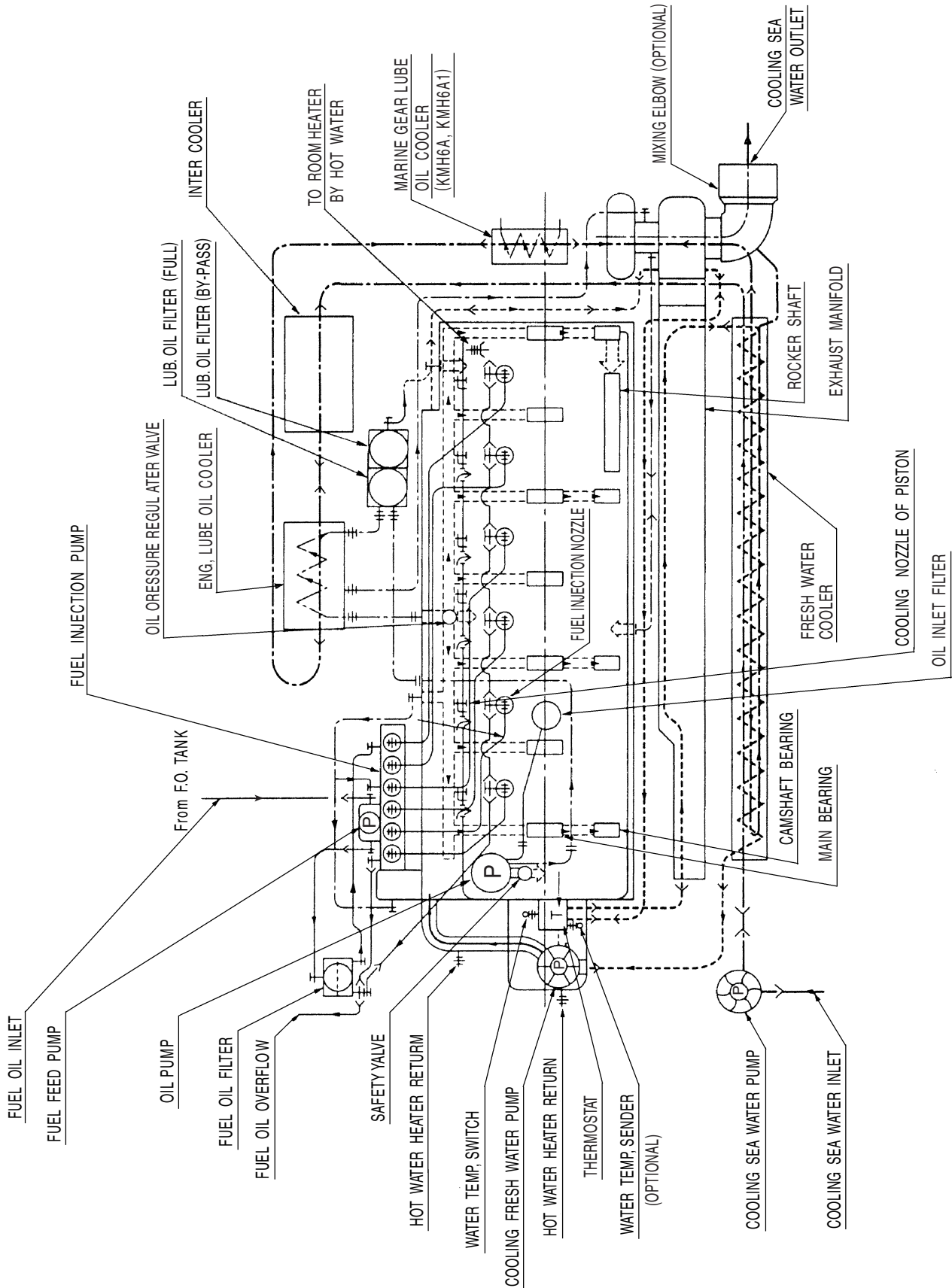

# 6.2 Wiring diagram

## (1) New B-type Control panel

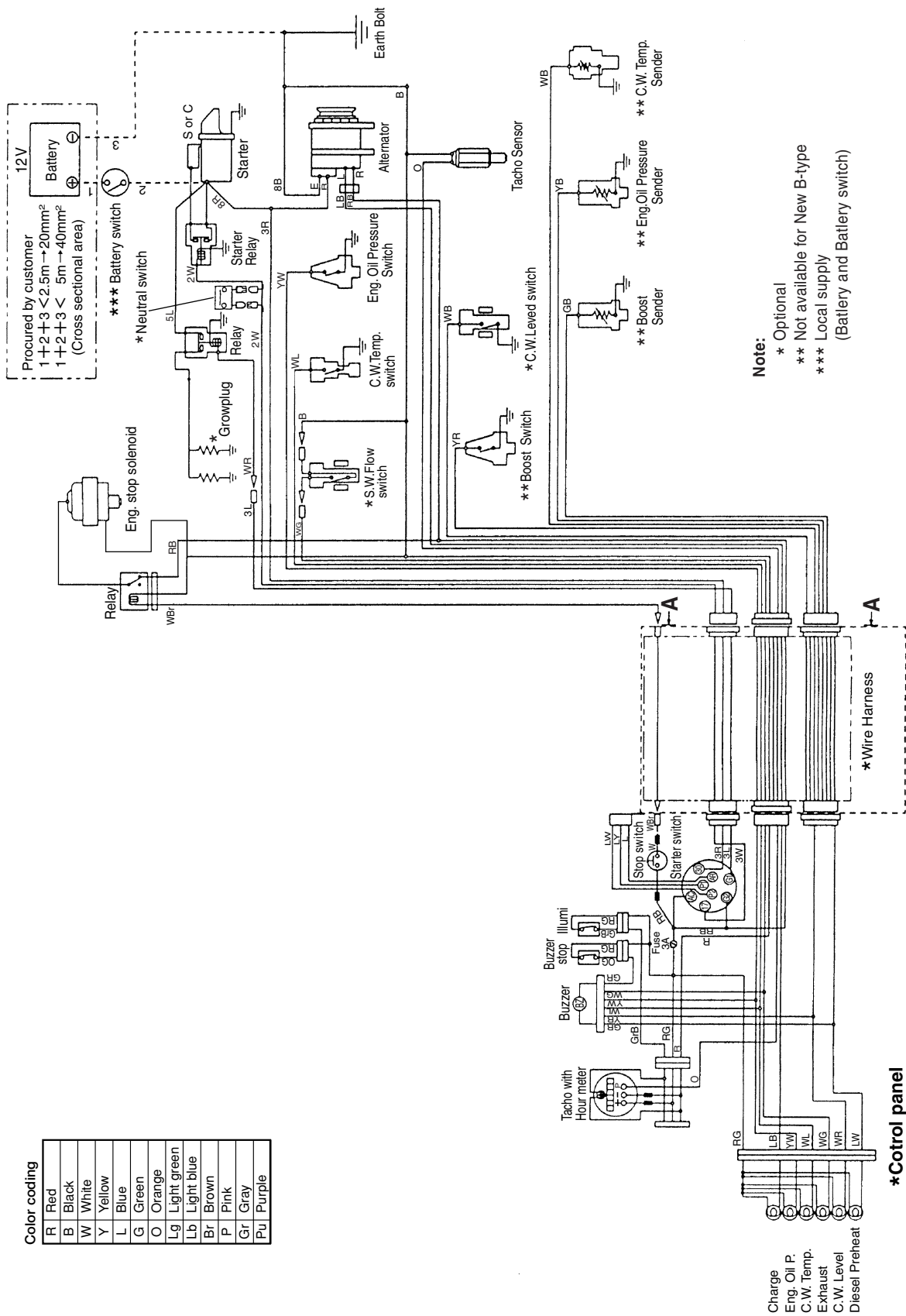

## (2) New C-type control panel

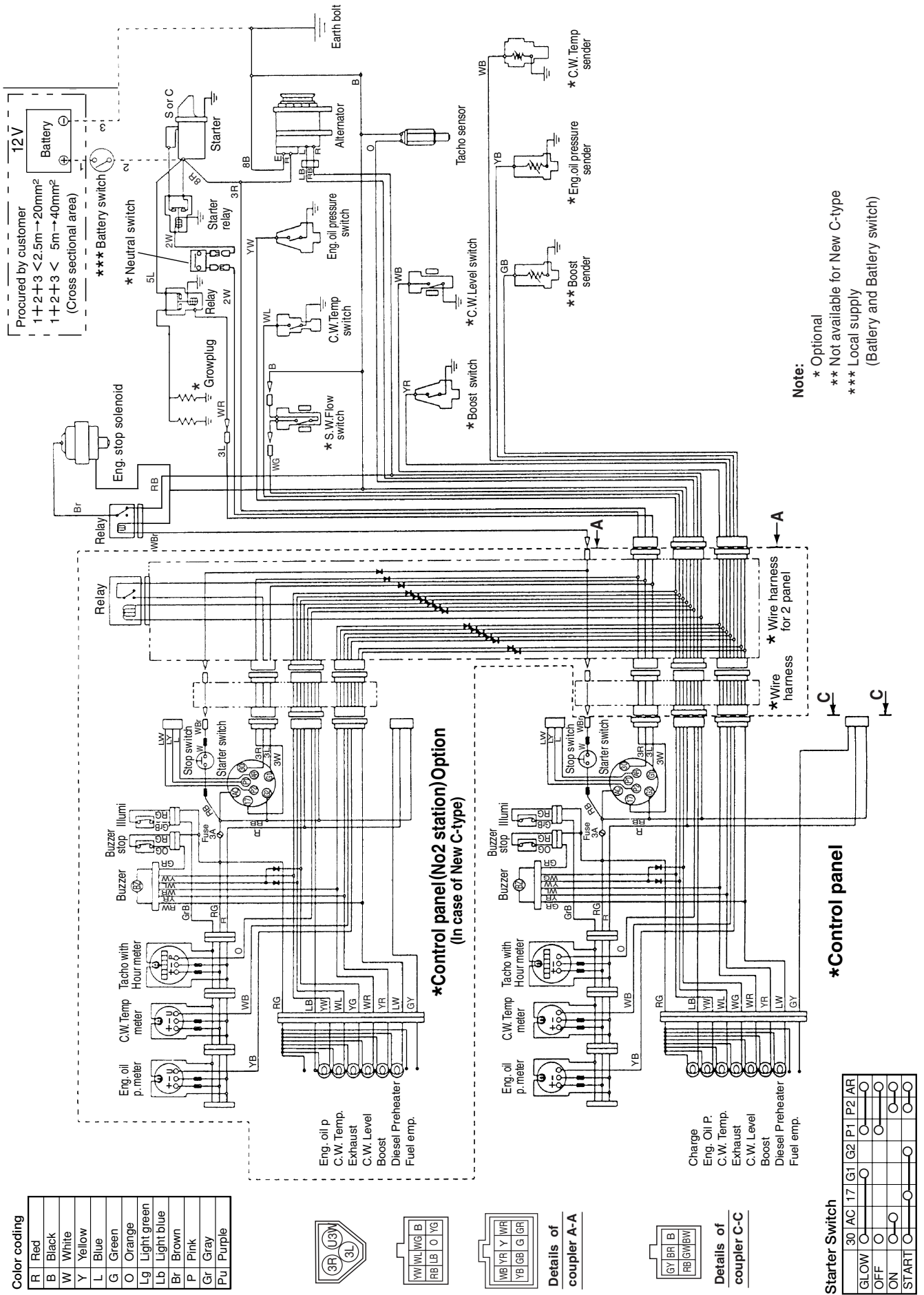

### (3) New D-type control panel

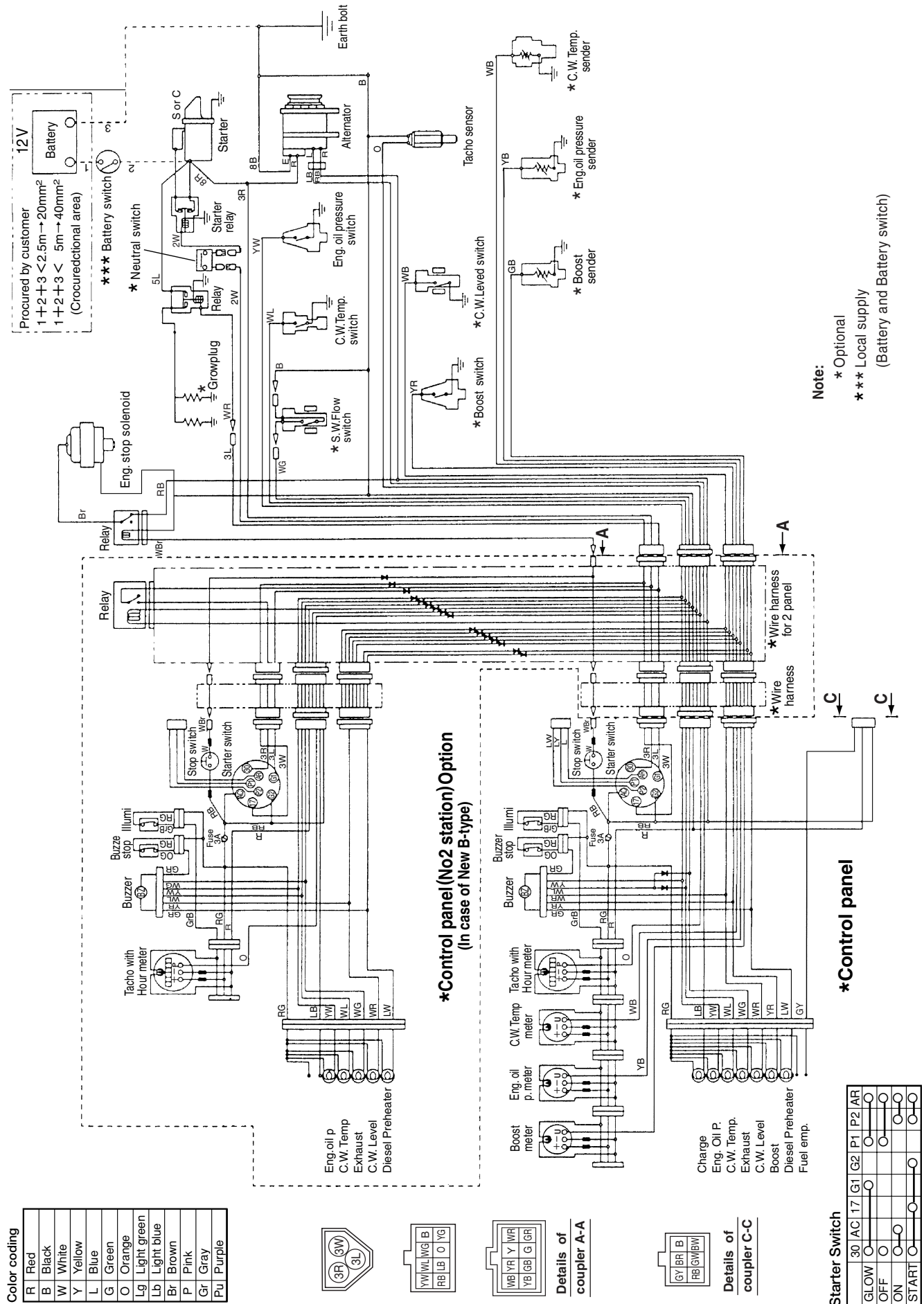

# WARRANTY SERVICE

## Owner Satisfaction

Your satisfaction and good will are important to your dealer and to us.

Normally, any problems concerning the product will be handled by our dealer's service department. If you have a warranty problem that has not been handled to your satisfaction, we suggest you take the following action:

- Discuss your problem with a member of dealership management. Often complaints can be quickly resolved at that level. If the problem has already been reviewed with the Service Manager, contact the owner of the dealership or the General Manager.
- If your problem still has not been resolved to your satisfaction, contact your Yanmar local Subsidiary Company.

### **YANMAR DIESEL AMERICA CORP.**

951 Corporate Grove Drive, Buffalo Grove, IL 60089-4508, U.S.A

TEL: (847) 541-1900

FAX: (847) 541-2161

### **YANMAR EUROPE B. V.**

Bruegplein 11, 1332 BS Almere-De Vaart, P.O. Box 30112,  
1303 AC Almere, The Netherlands

TEL: 36-5493200

FAX: 36-5493209

TELEX: 70732 YMR A NL

### **YANMAR ASIA (SINGAPORE) CORPORATION PTE LTD.**

4 Tuas Lane, Singapore 2263

TEL: 861-3855

FAX: 862-5195

TELEX: RS 35854 YANMAR

We will need the following information in order to assist you:

- Your name, address and telephone number
- Product model and serial number (see the name plate affixed on the engine)
- Date of purchase
- Dealer name and address
- Nature of problem

After reviewing all the facts involved, you will be advised of what action can be taken. Please bear in mind that your problem will likely be resolved at the dealership, using the dealer's facilities, equipment and personnel, so it is very important that your initial contact will be with the dealer.



# **YANMAR DIESEL ENGINE CO.,LTD.**

## **OVERSEAS OPERATIONS DIVISION**

1-32, CHAYAMACHI, KITA-KU, OSAKA 530-8311, JAPAN

TEL : 81-6-6376-6411

FAX : 81-6-6377-1242

## **YANMAR DIESEL AMERICA CORP.**

951 CORPORATE GROVE DRIVE, BUFFALO GROVE, IL 60089-4508, U.S.A.

TEL : 1-847-541-1900

FAX : 1-847-541-2161

## **YANMAR EUROPE B.V.**

BRUGPLEIN 11, 1332 BS ALMERE-DE VAART, THE NETHERLANDS P.O. BOX 30112, 1303

TEL : 31-36-5493200

FAX : 31-36-5493209

## **YANMAR ASIA (SINGAPORE) CORPORATION PTE LTD.**

4 TUAS LANE. SINGAPORE 638613

TEL : 65-861-3855

FAX : 65-862-5195

User's record

Date of purchase

Place of purchase (Name of dealer)